

Hydraport Hydraulics

Ball Valve
Ball Valve Annex
Check Valve
Shuttle Valve
Control Valve
Counterbalance Valve

Testing Tools
Accumulator



Hydraport Hydraulics
7519 Sideroad 7 E, Kenilworth, ON
N0G2E0, Canada
contact@hydraportmfg.com
226-770-0219
www.hydraportmfg.com



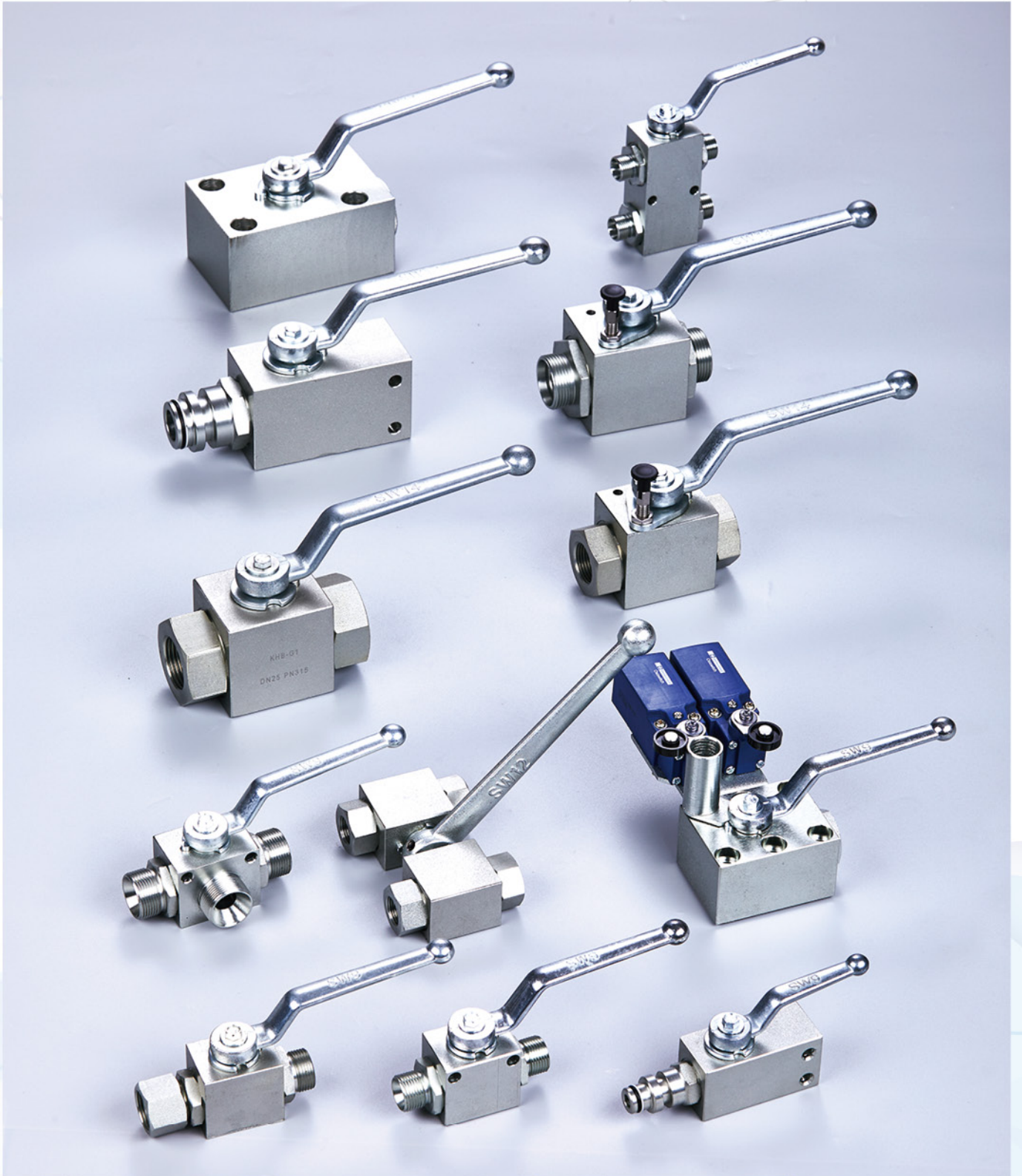



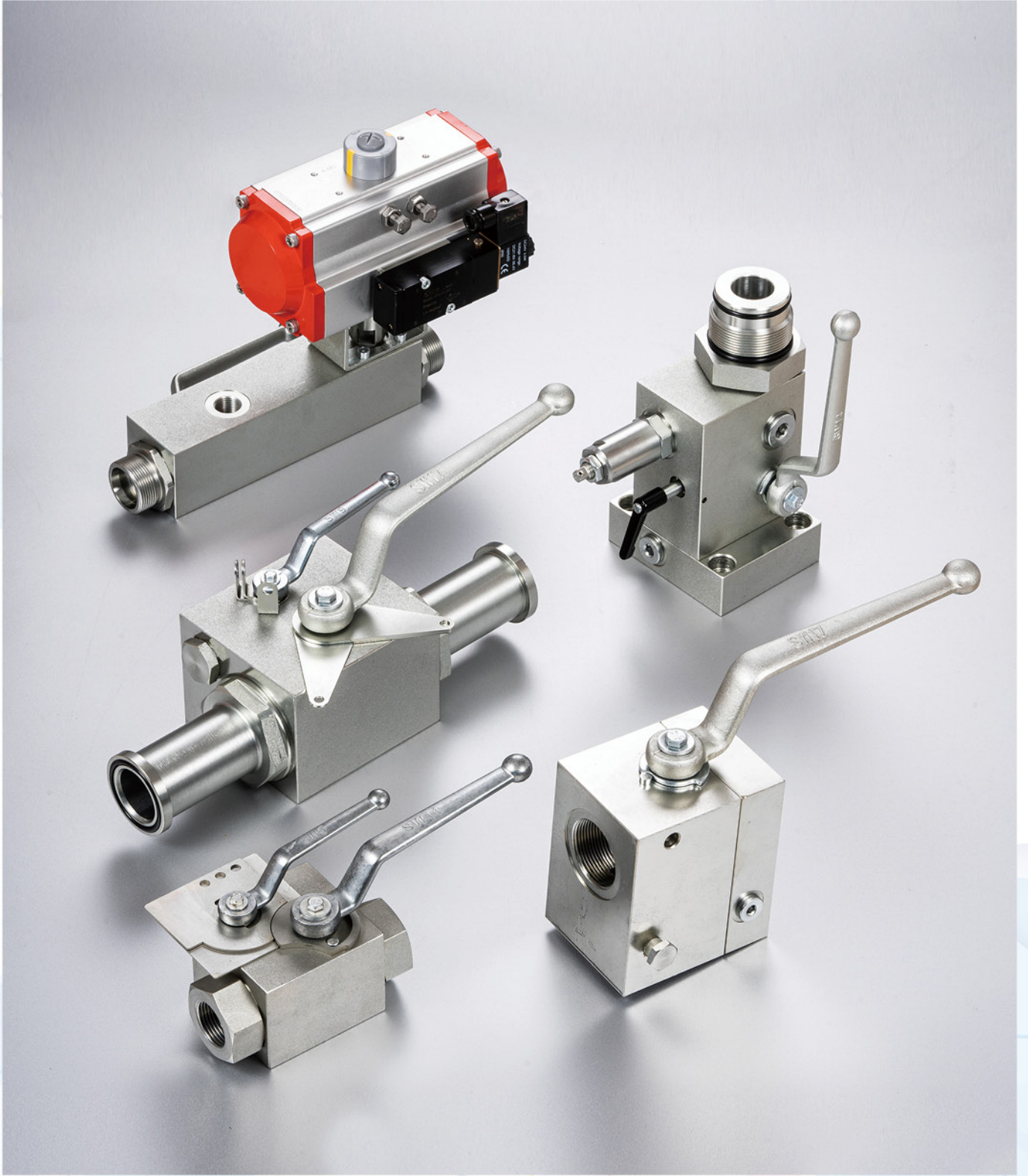









THREAD CONNECTIONS SERIES

	KHB, KHM Series Two Way Hydraulic Ball Valve	4
	KHB3K Series Three Way Hydraulic Ball Valve	8
	KHB, KHM Series Two-way Hydraulic Ball Valve Combinations	12
	KHB3K Series Three-way Hydraulic Ball Valve Combinations	13
	KH3, KH4 Series Multiway Ball Valve	14





MANIFOLD MOUNTING SERIES

	KHP Series Manifold Mounting Ball Valves	18
	KHP3K Series Manifold Mounting Ball Valves	19
	KH3P, KH4P Series Multiway Ball Valve For Manifold Mounting	20







FLANGE CONNECTIONS SERIES

	KHB-F3/6, KHM-F3/6 Series Ball Valve With SAE Connection	23
	2-way Ball Valves With SAE Connection	25
	KHZ Series Ball Valve With SAE Connection	26
	KH2K Series Two Way Ball Valve With SAE Flange (Manifold Mounting)	28
	KH3K Series Three Way Compact Ball Valve With SAE Connection	29
	BKH-SAE, MKH-SAE Series Ball Valve With SAE Connection	30
	SAE Flange Ball Valve One End With SAE Split Flange Adapter, Other End With SAE Adapter Metric	32
	SAE Flange Ball Valve One End With SAE Long Split Flange Adapter, Other End With SAE Adapter Metric	34
	BKH-SAE-FS, MKH-SAE-FS Ball Valve With SAE Split Flange Adapter	36
	BKH-SAEFS-Lu, MKH-SAEFS-Lu With SAE Long Split Flange Connection	38
	KH Ball Valve With ISO SAE Connection	40
	KHBF, KHMF Series Ball Valves With DIN Connections	41

OTHER SERIES HYDRAULIC BALL VALVE

	KHB-NZ Series 60° Internal Taper Seal Hydraulic Ball Valve	43
	KHB3K-NZ Series 60° Internal Taper Seal Hydraulic Ball Valve	44
	GB3V Series Three Way Hydraulic Ball Valve	45
	BBKH-FF/FM Series Hydraulic Ball Valve	46

**OTHER SERIES HYDRAULIC BALL VALVE**

	KHB-NSL Series Combinations -----	47
	FCBV06-04G-04G Flow Control Check Ball Valve -----	48
	KHB Series Right-angle Articulated Hydraulic Ball Valve -----	49
	HKHB Series Two Way Ball Valve -----	50
	PTH Bypass Ball Valve -----	51
	XHF Safety bleed valve -----	52
	Ball Valve With Welded Mounting Plate Series -----	53



LOW PRESSURE SERIES

	Low Pressure Ball Valves With Threaded Connection -----	55
---	---	----

BALL VALVE ANNEX (ACCESSORY)

	Ball Valve Annex: Accessory Levers -----	56
	Ball Valve Annex: Accessory Ball Valve Mounting Holes Series -----	57
	Ball Valve Annex: Accessory KHB, KHM Series With Pneumatic Actuator -----	59
	Ball Valve Annex: Accessory DW Spring Pin -----	60
	Ball Valve Annex: Accessory Ball Valves Locking Devices DS Series -----	61
	Ball Valve Annex: Accessory Ball Valves Locking Devices DST Series -----	62
	Ball Valve Annex: Accessory Ball Valves Locking Devices DXT Series -----	63
	Ball Valve Annex: Accessory Ball Valves Locking Devices DSP Series -----	64
	Ball Valve Annex: Accessory Set With Mechanical Limit Switch -----	65
	Ball Valve Annex: Accessory Set With Mechanical Limit Switch & Locking Device -----	66

CHECK VALVE SERIES

	HSP Series Check Valves -----	67
	ATR Series Check Valves -----	68

FLOW CONTROL (CHECK) VALVES

	L Series Flow Control Valve / LA Series Flow Control Check Valve -----	69
---	--	----

PLUG VALVES SERIES









	DF3 Series Plug Valve -----	72
	0CUKAC2318 Series Combinations Plug valve -----	73



SHUTTLE VALVE

	VUSF Series Shuttle Valve	74
---	---------------------------------	----

OPERATED CHECK VALVES SERIES

	VBPSE Single Pilot Operated Check Valve	75
	VBPDE Double Pilot Operated Check Valve	76
	VBPSE-FL Series Single Pilot Operated Check Valve	77
	VBPDE-FL Series Double Pilot Operated Check Valve	78
	VBPDC Series Double Pilot Operated Check Valve	79
	VRPE Series Single Pilot Operated Check Valve	80
	Pilot Operated Check Valve For Double Acting Cylinder	
	Pilot Operated Check Valve For Single Acting Cylinder	



COUNTERBALANCE VALVE

	VBSO Series Counterbalance Valve	81
---	--	----

OVERCENTER VALVES

	VBCD-DE-FLV Series Double Overcenter Valves Fixing By Screw	85
---	---	----

PRESSURE TESTING TOOLS

	Pressure Testing Adaptor	86
	Pressure Testing Hose Assembly	88







NITROGEN CHARGING SERIES

	CDZ-D3 Nitrogen Charging Cart	90
	FPU Multi-function Inflatable Kit	92

ACCUMULATOR SAFETY BLOCKS

	SAF Series Accumulator Safety Block	94
---	---	----

ACCUMULATOR

	Introduction to Bladder Accumulators	101
	American Standard Accumulators (ASME)	102
	European Standard Accumulators	104
	National Standard (CE marking) Accumulators	105
	National Standard (ABS American Bureau Of Shipping Certification) Accumulators	106
	Welded Diaphragm Accumulator	107



How to order

KHB - G1/2 - 1 1 1 2 - 04 - Accessory

[1] [2] [3] [4] [5] [6] [7] [8]

[1] Model: KHB-Square body DN04-DN25

KHM-Eight-Square body DN32- DN50

[2] Threaded connection type for adapter, e.g. G1/2

[3] Body and Connection material: 1-Carbon steel

4-Stainless steel

[4] Ball & stem material: 1-Carbon steel; 4-Stainless steel

[5] Ball seat material: 1-POM; 4-PTFE; 5-PEEK

[6] Connection & stem seal: 2-NBR; 4-FPM; 6-EPDM

[7] Levers type: 04-Zinc Alloy Bent levers

05-Steel Straight levers

06-Steel Bent levers

[8] Valve can be offered with locking device or any other accessory like limit switches or actuators. Please check *Ball Valve Annex for more information

General dimensions

KHB

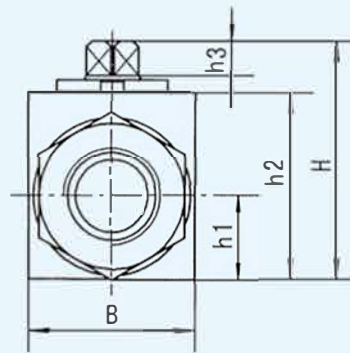
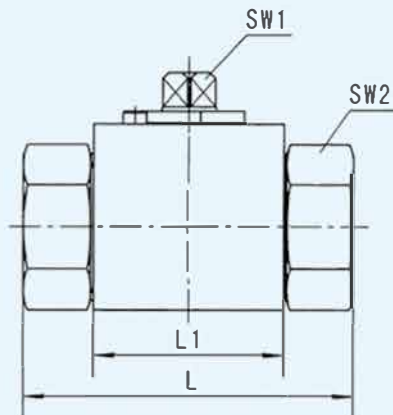

KHM

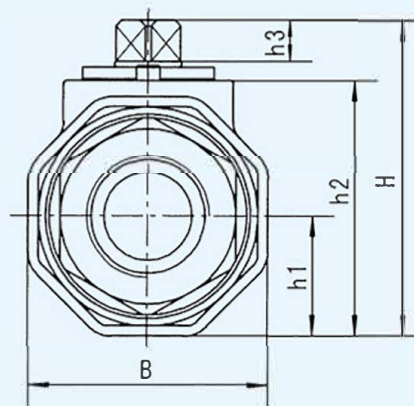
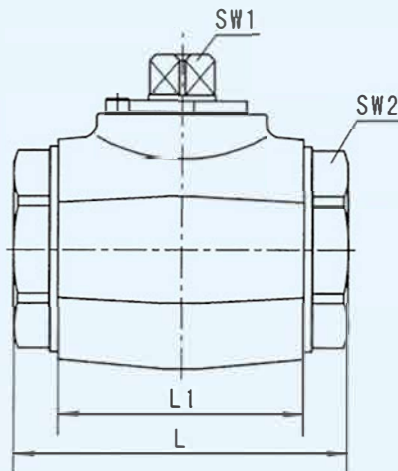

The Product selection codes 3, 4, 5, and 6, which corresponds to the 1,1,1, and 2 configuration, is the default standard combination. No additional labeling is required unless there are specific requirements.

JB984-77 Male Metric Thread

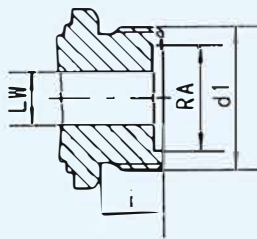

Model	DN	PN	LW	RA	d1	i	L	L1	B	H	h1	h2	h3	SW1	SW2
KHB-M12×1.25	4	500	4	8	M12×1.25	9	61	37	28	44.5	13	32	8	9	22
KHB-M16×1.5	6	500	6	11	M16×1.5	11	69	37	28	44.5	13	32	8	9	22
KHB-M22×1.5	8	500	8	16	M22×1.5	12	76	42	32	52.5	17	40	8	9	27
KHB-M27×1.5	10	500	10	20	M27×1.5	12	76	42	32	52.5	17	40	8	9	30
KHB-M30×1.5	16	400	15	24	M30×1.5	13	84	47	38	63.5	19	46	11	12	32
KHB-M36×2	20	315	20	30	M36×2	15	103	60	48	75	24	57	12	14	41
KHB-M42×2	25	315	25	35	M42×2	18	116	65	57	82	28.5	64	12	14	50
KHM-M52×2	32	315	30	40	M52×2	20	149	84	82	108	41	87.5	14	17	60
KHM-M60×2	40	315	38	50	M60×2	22	174	91	93	119.5	46.5	99	14	17	70
KHM-M72×2	50	315	48	60	M72×2	24	178	100	110	135.5	55	115	14	17	80

ISO 228 Female Thread

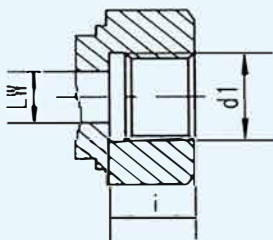

Model	DN	PN	LW	d1	i	L	L1	B	H	h1	h2	h3	SW1	SW2
KHB-G1/8	4	500	6	G1/8	10	69	37	28	44.5	13	32	8	9	22
KHB-G1/4	6	500	6	G1/4	14	69	37	28	44.5	13	32	8	9	22
KHB-G3/8	10	500	10	G3/8	14	72	42	32	52.5	17	40	8	9	27
KHB-G1/2-SW9	13	500	13	G1/2	16	83	48	35	52.5	17	40	8	9	30
KHB-G1/2-SW12	16	400	15	G1/2	16	83	47	38	63.5	19	46	11	12	32
KHB-G5/8	16	400	15	G5/8	16	88	47	38	63.5	19	46	11	12	32
KHB-G3/4	20	315	20	G3/4	18	95	60	48	75	24	57	12	14	41
KHB-G1	25	315	25	G1	20.5	113	65	57	82	28.5	64	12	14	50
KHB-G1 1/4	25/32	315	25	G1 1/4	22	120	65	60	82	28.5	64	12	14	55
KHB-G1 1/2	25/40	315	25	G1 1/2	24	130	65	60	82	28.5	64	12	14	60
KHM-G1 1/4	32	315	30	G1 1/4	22	110	84	82	108	41	87.5	14	17	60
KHM-G1 1/2	40	315	38	G1 1/2	24	130	91	93	119.5	46.5	99	14	17	70
KHM-G2	50	315	48	G2	26	140	100	110	135.5	55	115	14	17	80

ANSI B1.20.1 NPT Female Thread

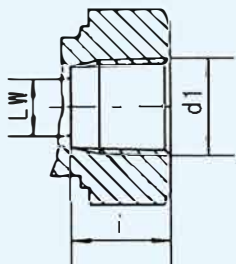

Model	DN	PN	LW	d1	i	L	L1	B	H	h1	h2	h3	SW1	SW2
KHB-1/8NPT	4	500	6	1/8NPT	10.5	69	37	28	44.5	13	32	8	9	22
KHB-1/4NPT	6	500	6	1/4NPT	14	69	37	28	44.5	13	32	8	9	22
KHB-3/8NPT	10	500	10	3/8NPT	14	72	42	32	52.5	17	40	8	9	27
KHB-1/2NPT	13	500	13	1/2NPT	17	83	48	35	52.5	17	40	8	9	30
KHB-3/4NPT	20	315	20	3/4NPT	19	95	60	48	75	24	57	12	14	41
KHB-1 NPT	25	315	25	1 NPT	22.5	113	65	57	82	28.5	64	12	14	50
KHB-1 1/4NPT	25/32	315	25	1 1/4NPT	22.5	120	65	60	82	28.5	64	12	14	55
KHB-1 1/2NPT	25/40	315	25	1 1/2NPT	25	130	65	60	82	28.5	64	12	14	60
KHM-1 1/4NPT	32	315	30	1 1/4NPT	25	120	84	82	108	41	87.5	14	17	60
KHM-1 1/2NPT	40	315	38	1 1/2NPT	25	130	91	93	119.5	46.5	99	14	17	70
KHM-2 NPT	50	315	48	2 NPT	30	140	100	110	135.5	55	115	14	17	80



SSAE J514/ISO/DIS11926-1 Metric Thread

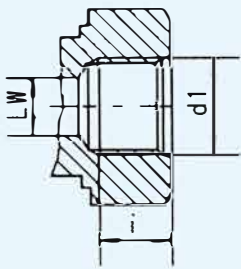

Model	DN	PN	LW	d1	i	L	L1	B	H	h1	h2	h3	SW1	SW2
KHB-SAE4	6	500	6	7/16-20UNF	12	69	37	28	44.5	13	32	8	9	22
KHB-SAE6	10	500	10	9/16-18UNF	13	72	42	32	52.5	17	40	8	9	27
KHB-SAE8	13	500	13	3/4-16UNF	15	83	48	35	52.5	17	40	8	9	30
KHB-SAE12	20	315	20	1 1/16-12UN	20	95	60	48	75	24	57	12	14	41
KHB-SAE16	25	315	25	1 5/16-12UN	20	113	65	57	82	28.5	64	12	14	50
KHB-SAE20	25/32	315	25	1 9/8-12UN	20	120	65	60	82	28.5	64	12	14	55
KHB-SAE24	25/40	315	25	1 7/8-12UN	20	130	65	60	82	28.5	64	12	14	60
KHM-SAE20	32	315	30	1 9/8-12UN	20	120	84	82	108	41	87.5	14	17	60
KHM-SAE24	40	315	38	1 7/8-12UN	20	130	91	93	119.5	46.5	99	14	17	70
KHM-SAE32	50	315	48	2 1/2-12UN	20	140	100	110	135.5	55	115	14	17	80

DIN 2353 / ISO 84341 Light Series

Please note the pressure ratings of the connection

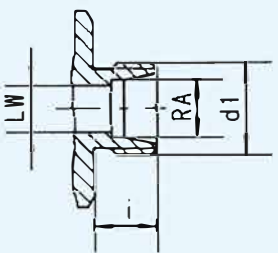

Model	DN	PN	LW	RA	d1	i	L	L1	B	H	h1	h2	h3	SW1	SW2
KHB-06LR	4	500	4	6	M12×1.5	10	67	37	28	44.5	13	32	8	9	22
KHB-08LR	6	500	6	8	M14×1.5	10	67	37	28	44.5	13	32	8	9	22
KHB-10LR	8	500	8	10	M16×1.5	11	74	42	32	52.5	17	40	8	9	27
KHB-12LR	10	500	10	12	M18×1.5	11	74	42	32	52.5	17	40	8	9	27
KHB-15LR-SW9	13	500	13	15	M22×1.5	12	82	48	35	52.5	17	40	8	9	30
KHB-15LR-SW12	13	400	13	15	M22×1.5	12	82	47	38	63.5	19	46	11	12	32
KHB-18LR-SW9	13	500	13	18	M26×1.5	12	82	48	35	52.5	17	40	8	9	30
KHB-18LR-SW12	16	400	15	18	M26×1.5	12	82	47	38	63.5	19	46	11	12	32
KHB-22LR	20	315	19	22	M30×2	14	101	60	48	75	24	57	12	14	41
KHB-28LR	25	315	25	28	M36×2	14	108	65	57	82	28.5	64	12	14	50
KHB-35LR	25/32	315	25	35	M45×2	16	112	65	60	82	28.5	64	12	14	50
KHM-35LR	32	315	30	35	M45×2	16	141	84	82	108	41	87.5	14	17	60
KHM-42LR	40	315	38	42	M52×2	16	162	91	93	119.5	46.5	99	14	17	70

DIN 2353 / ISO 8434-1 Heavy Series

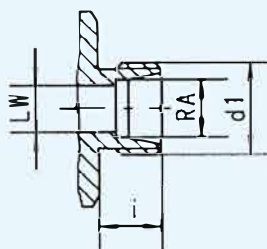

Model	DN	PN	LW	RA	d1	i	L	L1	B	H	h1	h2	h3	SW1	SW2
KHB-08SR	4	500	5	8	M16×1.5	12	73	37	28	44.5	13	32	8	9	22
KHB-10SR	6	500	6	10	M18×1.5	12	73	37	28	44.5	13	32	8	9	22
KHB-12SR	8	500	8	12	M20×1.5	12	76	42	32	52.5	17	40	8	9	27
KHB-14SR	10	500	10	14	M22×1.5	14	80	42	32	52.5	17	40	8	9	27
KHB-16SR-SW9	13	500	13	16	M24×1.5	14	86	48	35	52.5	17	40	8	9	30
KHB-16SR-SW12	13	400	13	16	M24×1.5	14	86	47	38	63.5	19	46	11	12	32
KHB-20SR-SW9	13	500	13	20	M30×2	16	90	48	35	52.5	17	40	8	9	32
KHB-20SR-SW12	16	400	15	20	M30×2	16	90	47	38	63.5	19	46	11	12	32
KHB-25SR	20	315	20	25	M36×2	18	109	60	48	75	24	57	12	14	41
KHB-30SR	25	315	25	30	M42×2	20	120	65	57	82	28.5	64	12	14	50
KHB-38SR	25/32	315	25	38	M52×2	22	124	65	60	82	28.5	64	12	14	55
KHM-38SR	32	315	30	38	M52×2	22	153	84	82	108	41	87.5	14	17	60

Note: The unit of DN is mm, and the unit of PN is bar.

Metric Female Thread

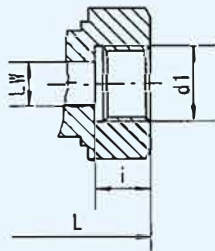

Model	DN	PN	LW	d1	i	L	L1	B	H	h1	h2	h3	SW1	SW2
KHB-N-M14×1.5	6	500	6	M14×1.5	14	69	37	28	44.5	13	32	8	9	22
KHB-N-M18×1.5	10	500	10	M18×1.5	13	72	42	32	52.5	17	40	8	9	27
KHB-N-M22×1.5-SW9	13	500	13	M22×1.5	15	83	48	35	52.5	17	40	8	9	30
KHB-N-M22×1.5-SW12	16	400	15	M22×1.5	16	83	47	38	63.5	19	46	11	12	32
KHB-N-M27×2	20	315	20	M27×2	18	95	60	48	75	24	57	12	14	41
KHB-N-M33×2	25	315	25	M33×2	20	113	65	57	82	28.5	64	12	14	50
KHM-N-M42×2	32	315	30	M42×2	22	120	84	82	108	41	87.5	14	17	60
KHM-N-M48×2	40	315	38	M48×2	24	130	91	93	119.5	46.5	99	14	17	70
KHM-N-M60×2	50	315	48	M60×2	26	140	100	110	135.5	55	115	14	17	80

ISO 7/1 Rc Female Thread

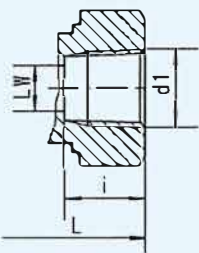

Model	DN	PN	LW	d1	i	L	L1	B	H	h1	h2	h3	SW1	SW2
KHB-1/4BSPT	6	500	6	Rc1/4	14	69	37	28	44.5	13	32	8	9	22
KHB-3/8BSPT	10	500	10	Rc3/8	14	72	42	32	52.5	17	40	8	9	27
KHB-1/2BSPT	13	500	13	Rc1/2	17	83	48	35	52.5	17	40	8	9	30
KHB-3/4BSPT	20	315	20	Rc3/4	20	95	60	48	75	24	57	12	14	41
KHB-1BSPT	25	315	25	Rc1	22.5	113	65	57	82	28.5	64	12	14	50
KHM-1 1/4BSPT	32	315	30	Rc1 1/4	25	120	84	82	108	41	87.5	14	17	60
KHM-1 1/2BSPT	40	315	38	Rc1 1/2	25	130	91	93	119.5	46.5	99	14	17	70
KHM-2BSPT	50	315	48	Rc2	30	140	100	110	135.5	55	115	14	17	80

Note: The unit of DN is mm, and the unit of PN is bar.

Ordering and Usage Notes

1. The selection for ordering codes 3, 4, 5, and 6, which corresponds to the 1,1,1, and 2 configuration, is the default standard combination. No additional labeling is required unless there are specific requirements.
2. The connection method of valve body and adapters is threaded, the standard is GB/T 193.
3. ODM or OEM Available



How to order

KHB3K	- G1/2	- L	- 1	1	1	2	- 04	- Accessory
[1]	[2]	[3]	[4]	[5]	[6]	[7]	[8]	[9]

- [1] Model: KHB3K-Square Body DN04-50
- [2] Threaded connection type for adapter: e.g. G1/2
- [3] Porting patterns: See chart of porting pattern DN04~DN50
- [4] Body and Connection: 1-Carbon steel
4-Stainless steel
- [5] Ball & stem material: 1-Carbon steel; 4-Stainless steel
- [6] Ball seat material: 1-POM; 4-PTFE; 5-PEEK
- [7] Connection & stem seal: 2-NBR; 4-FPM; 6-EPDM
- [8] Levers type: 04-Zinc Alloy Bent levers
05-Steel Straight levers
06-Steel Bent levers
- [9] Valve can be offered with locking device or any other accessory like limit switches or actuators. Please check *Ball Valve Annex for more information

Porting patterns (See chart)

ATTENTION: Hydraulic oil can flow into the valve through port "1" !
The valve can only be sealed under two specific situations:
(1) Pressure at the closed port is zero;
(2) Pressure at the closed port is lower than at the two open ports.
(3) Please order Model KHB3KS in case you need pressure inlet from all ports.

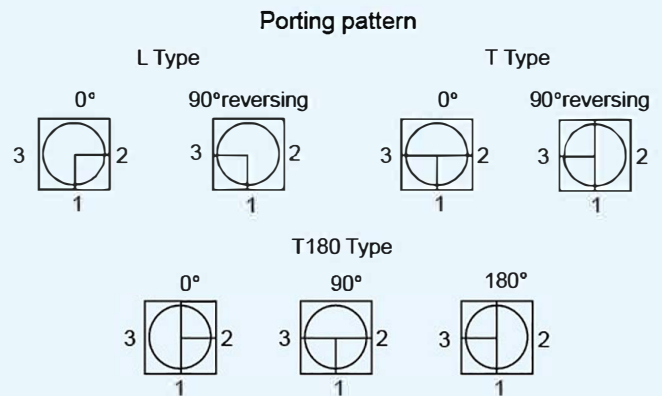

General dimensions

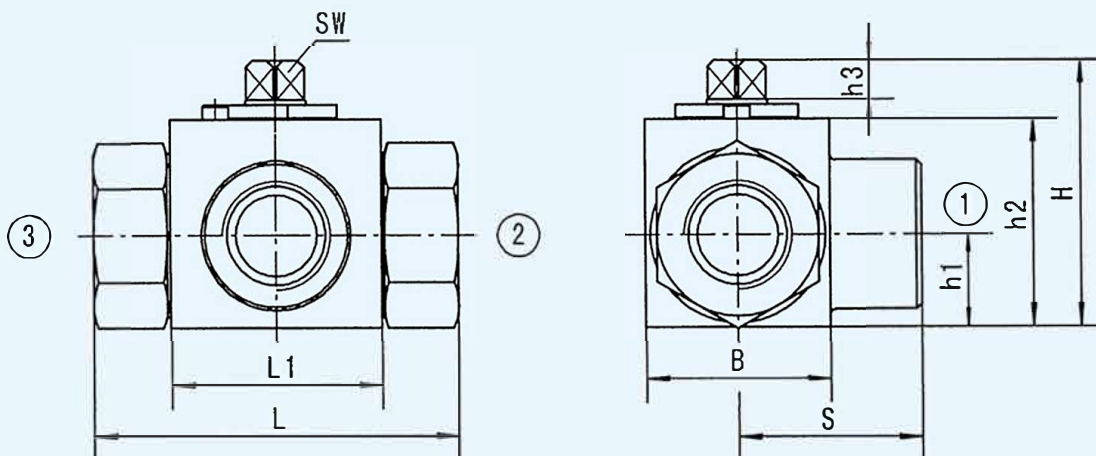

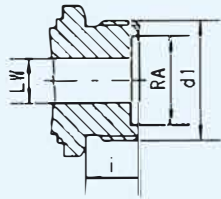
JB984-77 Male Metric Thread

Model	DN	PN	LW	RA	d1	i	L	L1	B	H	h1	h2	h3	SW	S
KHB3K-M12×1.25	4	315	4	8	M12×1.25	9	61	37	28	44.5	13	32	8	9	35
KHB3K-M16×1.5	6	315	6	11	M16×1.5	11	69	37	28	44.5	13	32	8	9	35
KHB3K-M22×1.5	8	315	8	16	M22×1.5	12	76	42	32	52.5	17	40	8	9	38
KHB3K-M27×1.5	10	315	10	20	M27×1.5	12	76	42	32	52.5	17	40	8	9	38
KHB3K-M30×1.5	16	315	15	24	M30×1.5	13	84	47	38	63.5	19	46	11	12	42
KHB3K-M36×2	20	315	20	30	M36×2	15	103	60	48	75	24	57	12	14	52
KHB3K-M42×2	25	315	25	35	M42×2	18	116	65	57	82	28.5	64	12	14	58
KHB3K-M52×2	32	315	30	40	M52×2	20	149	84	75	104.5	37.5	84	14	17	72
KHB3K-M60×2	40	315	38	50	M60×2	22	174	91	85	115.5	42.5	95	14	17	79.5
KHB3K-M72×2	50	315	48	60	M72×2	24	178	100	105	133	52.5	112.5	14	17	89

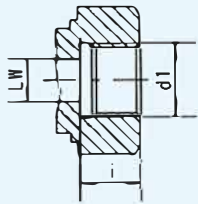
ISO 228 Female Thread

Model	DN	PN	LW	d1	i	L	L1	B	H	h1	h2	h3	SW	S
KHB3K-G1/8	4	500	6	G1/8	10	69	37	28	44.5	13	32	8	9	35
KHB3K-G1/4	6	500	6	G1/4	14	69	37	28	44.5	13	32	8	9	35
KHB3K-G3/8	10	500	10	G3/8	14	72	42	32	52.5	17	40	8	9	36
KHB3K-G1/2-SW9	13	500	13	G1/2	16	83	48	35	52.5	17	40	8	9	40
KHB3K-G1/2-SW12	16	400	15	G1/2	16	83	47	38	63.5	19	46	11	12	42
KHB3K-G3/4	20	315	20	G3/4	18	95	60	48	75	24	57	12	14	49
KHB3K-G1	25	315	25	G1	20.5	113	65	57	82	28.5	64	12	14	56.5
KHB3K-G1¼	25/32	315	25	G1¼	22	120	65	60	82	28.5	64	12	14	60
KHB3K-G1½	32	315	30	G1½	22	110	84	75	104.5	37.5	84	14	17	55
KHB3K-G1½	40	315	38	G1½	24	130	91	85	115.5	42.5	95	14	17	65
KHB3K-G2	50	315	48	G2	26	140	100	105	133	52.5	112.5	14	17	70

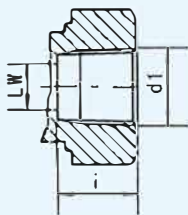
ANSI B1.20.1 NPT Female Thread

Model	DN	PN	LW	d1	i	L	L1	B	H	h1	h2	h3	SW	S
KHB3K-1/8NPT	4	500	6	1/8NPT	10.5	69	37	28	44.5	13	32	8	9	35
KHB3K-1/4NPT	6	500	6	1/4NPT	14	69	37	28	44.5	13	32	8	9	35
KHB3K-3/8NPT	10	500	10	3/8NPT	14	72	42	32	52.5	17	40	8	9	36
KHB3K-1/2NPT	13	500	13	1/2NPT	17	83	48	35	52.5	17	40	8	9	40
KHB3K-3/4NPT	20	315	20	3/4NPT	19	95	60	48	75	24	57	12	14	49
KHB3K-1 NPT	25	315	25	1 NPT	22.5	113	65	57	82	28.5	64	12	14	56.5
KHB3K-1¼NPT	25/32	315	25	1¼NPT	22.5	120	65	60	82	28.5	64	12	14	60
KHB3K-1½NPT	32	315	30	1½NPT	25	120	84	75	104.5	37.5	84	14	17	60
KHB3K-1½NPT	40	315	38	1½NPT	25	130	91	85	115.5	42.5	95	14	17	70
KHB3K-2 NPT	50	315	48	2 NPT	30	140	100	105	133	52.5	112.5	14	17	75



SSAE J514/ISO/DIS11926-1 Metric Thread

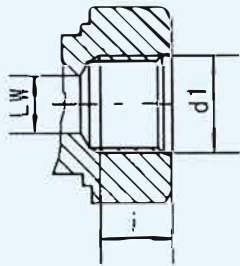

Model	DN	PN	LW	d1	i	L	L1	B	H	h1	h2	h3	SW1	S
KHB3K-SAE4	6	500	6	7/16-20UNF	12	69	37	28	44.5	13	32	8	9	35
KHB3K - SAE6	10	500	10	9/16-18UNF	13	72	42	32	52.5	17	40	8	9	36
KHB3K - SAE8	13	500	13	3/4-16UNF	15	83	48	35	52.5	17	40	8	9	40
KHB3K - SAE12	20	315	20	1 ¹ / ₁₆ -12UN	20	95	60	48	75	24	57	12	14	49
KHB3K - SAE16	25	315	25	1 ⁵ / ₁₆ -12UN	20	113	65	57	82	28.5	64	12	14	56.5
KHB3K - SAE20	25/32	315	25	1 ⁵ / ₈ -12UN	20	120	65	60	82	28.5	64	12	14	60
KHB3K - SAE20	32	315	30	1 ⁵ / ₈ -12UN	20	120	84	75	104.5	37.5	84	14	17	60
KHB3K - SAE24	40	315	38	1 ⁷ / ₈ -12UN	20	130	91	85	115.5	42.5	95	14	17	70
KHB3K - SAE32	50	315	48	2 ¹ / ₂ -12UN	20	140	100	105	133	52.5	112.5	14	17	75

DIN 2353 / ISO 8434-1 Light Series

Please note the pressure ratings of the connection

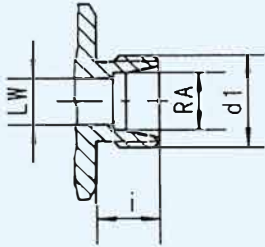

Model	DN	PN	LW	RA	d1	i	L	L1	B	H	h1	h2	h3	SW1	S
KHB3K -06LR	4	500	4	6	M12×1.5	10	67	37	28	44.5	13	32	8	9	34.5
KHB3K -08LR	6	500	6	8	M14×1.5	10	67	37	28	44.5	13	32	8	9	34.5
KHB3K -10LR	8	500	8	10	M16×1.5	11	74	42	32	52.5	17	40	8	9	37
KHB3K -12LR	10	500	10	12	M18×1.5	11	74	42	32	52.5	17	40	8	9	37
KHB3K -15LR-SW9	13	500	13	15	M22×1.5	12	82	48	35	52.5	17	40	8	9	40
KHB3K -15LR-SW12	13	400	13	15	M22×1.5	12	82	47	38	63.5	19	46	11	12	40
KHB3K -18LR-SW9	13	500	13	18	M26×1.5	12	82	48	35	52.5	17	40	8	9	42
KHB3K -18LR-SW12	16	400	15	18	M26×1.5	12	82	47	38	63.5	19	46	11	12	42
KHB3K -22LR	20	315	19	22	M30×2	14	101	60	48	75	24	57	12	14	52
KHB3K -28LR	25	315	25	28	M36×2	14	108	65	57	82	28.5	64	12	14	54
KHB3K -35LR	25/32	315	25	35	M45×2	16	112	65	60	82	28.2	64	12	14	56
KHB3K -35LR	32	315	30	35	M45×2	16	141	84	75	104.5	37.5	84	14	17	70.4
KHB3K -42LR	40	315	37	42	M52×2	16	162	91	85	115.2	42.5	95	14	17	81

DIN 2353 / ISO 8434-1 Heavy Series

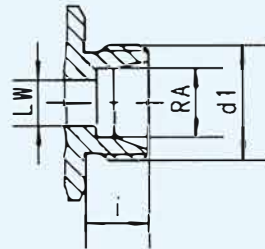

Model	DN	PN	LW	RA	d1	i	L	L1	B	H	h1	h2	h3	SW1	S
KHB3K -08SR	4	500	5	8	M16×1.5	12	73	37	28	44.5	13	32	8	9	37
KHB3K -10SR	6	500	6	10	M18×1.5	12	73	37	28	44.5	13	32	8	9	37
KHB3K -12SR	8	500	8	12	M20×1.5	12	76	42	32	52.5	17	40	8	9	38
KHB3K -14SR	10	500	10	14	M22×1.5	14	80	42	32	52.5	17	40	8	9	40
KHB3K -16SR-SW9	13	500	13	16	M24×1.5	14	86	48	35	52.5	17	40	8	9	43.5
KHB3K -16SR-SW12	13	400	13	16	M24×1.5	14	86	47	38	63.5	19	46	11	12	43.5
KHB3K -20SR-SW9	13	500	13	20	M30×2	16	90	48	35	52.5	17	40	8	9	45.5
KHB3K -20SR-SW12	16	400	15	20	M30×2	16	90	47	38	63.5	19	46	11	12	45.5
KHB3K -25SR	20	315	20	25	M36×2	18	109	60	48	75	24	57	12	14	56
KHB3K -30SR	25	315	25	30	M42×2	20	120	65	57	82	28.5	64	12	14	60
KHB3K -38SR	25/32	315	25	38	M52×2	22	124	65	60	82	28.5	64	12	14	62
KHB3K -38SR	32	315	30	38	M52×2	22	153	84	75	104.5	37.5	84	14	17	76.5

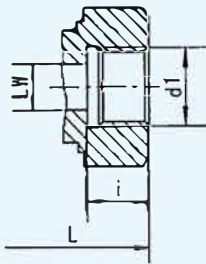
Metric Female Thread

Model	DN	PN	LW	d1	i	L	L1	B	H	h1	h2	h3	SW	S
KHB3K-N-M14×1.5	6	500	6	M14×1.5	13	69	37	28	44.5	13	32	8	9	35
KHB3K-N-M18×1.5	10	500	10	M18×1.5	13	72	42	32	52.5	17	40	8	9	36
KHB3K-N-M22×1.5-SW9	13	500	13	M22×1.5	15	83	48	35	52.5	17	40	8	9	40
KHB3K-N-M22×1.5-SW12	16	400	15	M22×1.5	16	83	47	38	63.5	19	46	11	12	42
KHB3K-N-M27×2	20	315	20	M27×2	18	95	60	48	75	24	57	12	14	49
KHB3K-N-M33×2	25	315	25	M33×2	20	113	65	57	82	28.5	64	12	14	56.5
KHB3K-N-M42×2	32	315	30	M42×2	22	110	84	75	104.5	37.5	84	14	17	55
KHB3K-N-M48×2	40	315	38	M48×2	24	130	91	85	115.5	42.5	95	14	17	65
KHB3K-N-M60×2	50	315	48	M60×2	26	140	100	105	133	52.5	112.5	14	17	75

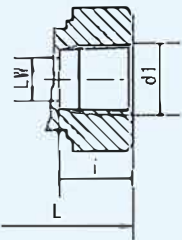
ISO 7/1 Rc Female Thread

Model	DN	PN	LW	d1	i	L	L1	B	H	h1	h2	h3	SW	S
KHB3K -1/8BSPT	4	500	6	Rc1/8	11	69	37	28	44.5	13	32	8	9	35
KHB3K -1/4BSPT	6	500	6	Rc1/4	14	69	37	28	44.5	13	32	8	9	35
KHB3K -3/8BSPT	10	500	10	Rc3/8	14	72	42	32	52.5	17	40	8	9	36
KHB3K -1/2BSPT	13	500	13	Rc1/2	17	83	48	35	52.5	17	40	8	9	40
KHB3K -3/4BSPT	20	315	20	Rc3/4	19	95	60	48	75	24	57	12	14	49
KHB3K -1BSPT	25	315	25	Rc1	22.5	113	65	57	82	28.5	64	12	14	56.5
KHB3K -1 1/4BSPT	25/32	315	25	Rc1 1/4	22.5	120	65	60	82	28.5	64	12	14	60

Note: The unit of DN is mm, and the unit of PN is bar.

Ordering and Usage Notes

1. The selection for ordering codes 4, 5, 6, and 7, which corresponds to the 1, 1, 1, and 2 configuration, is the default standard combination. No additional labeling is required unless there are specific requirements.
2. The connection method of valve body and adapters is threaded, the standard is GB/T 193.
3. ODM or OEM Available



How to order

KHB - ※ - **SL**
[1] [2]

[1] Model: Select according to KHB, KHM Series two-way ball valve

[2] Combination method

General dimensions

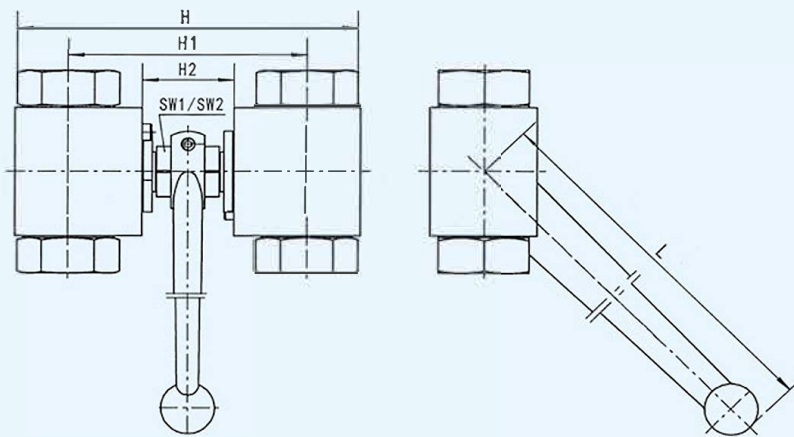

Model	DN	SW1	SW2	H	H1	H2	L
KHB-※-SL	4	9	12	90	64	26	180
KHB-※-SL	6	9	12	90	64	26	180
KHB-※-SL	8	9	12	106	72	26	180
KHB-※-SL	10	9	12	106	72	26	180
KHB-※-SL	13	9	12	106	72	26	180
KHB-※-SL	16	12	14	128	90	36	200
KHB-※-SL	20	14	17	155	107	41	260
KHB-※-SL	25	14	17	169	112	41	260
KHB-※-SL	25/32	14	17	169	112	41	260

Introduction

The KHB, KHM Series two-way Hydraulic Ball Valve Combinations combine the KHB or KHM series two-way hydraulic ball valves, this allowing you to select from all the threaded options available in the KHB or KHM series. The ball valves can be installed with side mounting holes or side mounting threaded holes. For specific models and sizes of individual ball valves, please refer to pages in the KHB, KHM Series Hydraulic ball valve catalog located in the front.

Ordering and Usage Notes

1. Just add -SL after KHB or KHM ball valve your select, you can easily get your KHB or KHM Series two-way Combinations.
2. KHB two way double ball valve, threaded M18 × 1,5, pipe diameter ϕ 12 light series, valve body joint material carbon steel, ball control spindle material stainless steel, sealing material POM at the ball, joint and control spindle sealing FPM, surface environmentally friendly zinc, model: KHB-12LR-1414-SL environmentally friendly zinc.



How to order

KHB3K - ※ - SL
 [1] [2]

- [1] Model: Select according to KHB3K, KHM3K Series three-way ball valve
- [2] Combination method

Dimensions

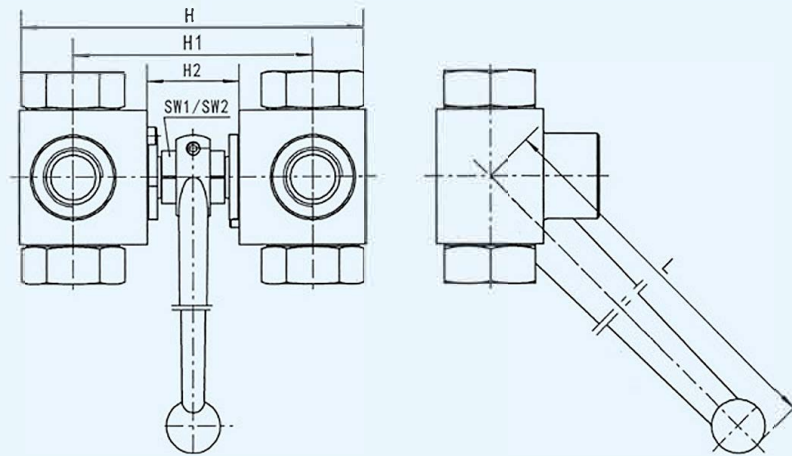

Model	DN	SW1	SW2	H	H1	H2	L
KHB3K-※-SL	4	9	12	90	64	26	180
KHB3K-※-SL	6	9	12	90	64	26	180
KHB3K-※-SL	8	9	12	106	72	26	180
KHB3K-※-SL	10	9	12	106	72	26	180
KHB3K-※-SL	13	9	12	106	72	26	180
KHB3K-※-SL	16	12	14	128	90	36	200
KHB3K-※-SL	20	14	17	155	107	41	260
KHB3K-※-SL	25	14	17	169	112	41	260
KHB3K-※-SL	25/32	14	17	169	112	41	260

Introduction

The KHB3K, KHM3K Series three-way Hydraulic Ball Valve Combinations combine the KHB3K, KHM3K series three-way hydraulic ball valves, this allowing you to select from all the threaded options available in the KHB3K or KHM3K series. The ball valves can be installed with side mounting holes or side mounting threaded holes. For specific models and sizes of individual ball valves, please refer to pages in the KHB3K, KHM3K Series Hydraulic ball valve catalog located in the front.

Ordering and Usage Notes

1. Just add -SL after KHB3K or KHM3K series ball valve your select, you can easily get your KHB3K or KHM3K three-way combinations.
2. KHB3K three-way double ball valve, thread M18×1,5, pipe diameter Φ12 light series, valve body joint material carbon steel, sphere control mandrel material stainless steel, sphere sealing material POM, joint and control mandrel sealing FPM, surface environmental protection zinc
 Model: KHB3K-12LL-1414-SL environmental protection zinc.



How to order

KH3	-	G1/2	-	L	-	1	1	1	2	-	SB01	-	04	-	Accessory
[1]		[2]		[3]		[4]	[5]	[6]	[7]		[8]		[9]		[10]



- [1] Model: KH3 - 3-way ball valve
KH4 - 4-way ball valve
 - [2] Threaded connection type for adapter
 - [3] Ball symbol: KH3-L
KH3-T
KH4-L
KH4-T
KH4-X
 - [4] Body and connection material: 1-Carbon steel
4-Stainless steel
 - [5] Ball & stem material: 1-Carbon steel
4-Stainless steel
 - [6] Ball seat material: 1-POM; 5-PEEK
 - [7] Connection & stem seal: 2-NBR
4-FKM
- Remark): Product selection codes 1112 is normal material, it could omit when place order.
- [8] Porting pattern: See chart of porting pattern
 - [9] Levers type: 04-Zinc Alloy Bent levers
05-Steel Straight levers
06-Steel Bent levers
 - [10] Valve can be offered with locking device or any other accessory like limit switches or actuators. Please check *Ball Valve Annex for more information

Porting patterns

3 way ball valve L type 90° operating angle, 45° closed

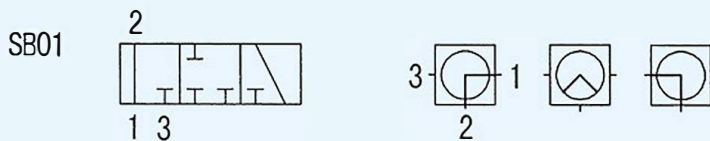

3 way ball valve T type 90° operating angle, 45° closed



3 way ball valve T type 90° operating angle



3 way ball valve T type 180° operating angle

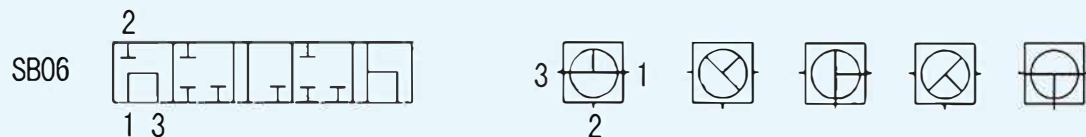
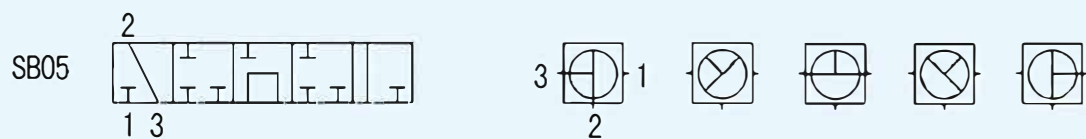
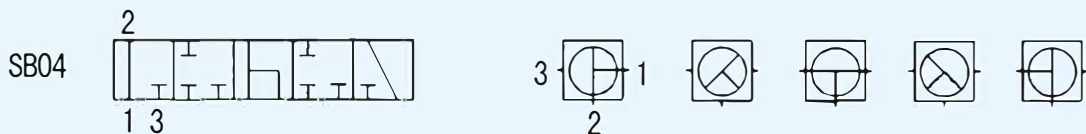

4 way ball valve L type 180° operating angle

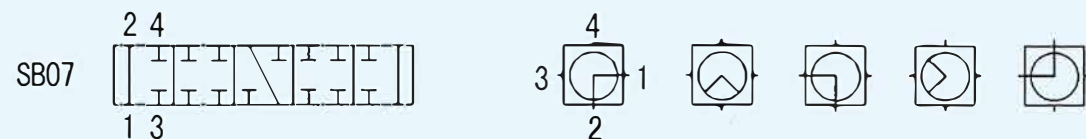

4 way ball valve T type 90° operating angle



4 way ball valve T type 180° operating angle

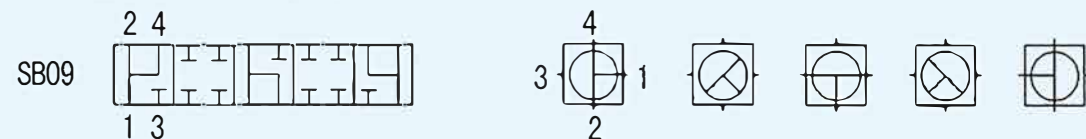

4 way ball valve X type 90° operating angle



This series of high pressure ball valve has three and four ways, you can have multiple control method, and find the best way to solve the fluid.



General dimensions

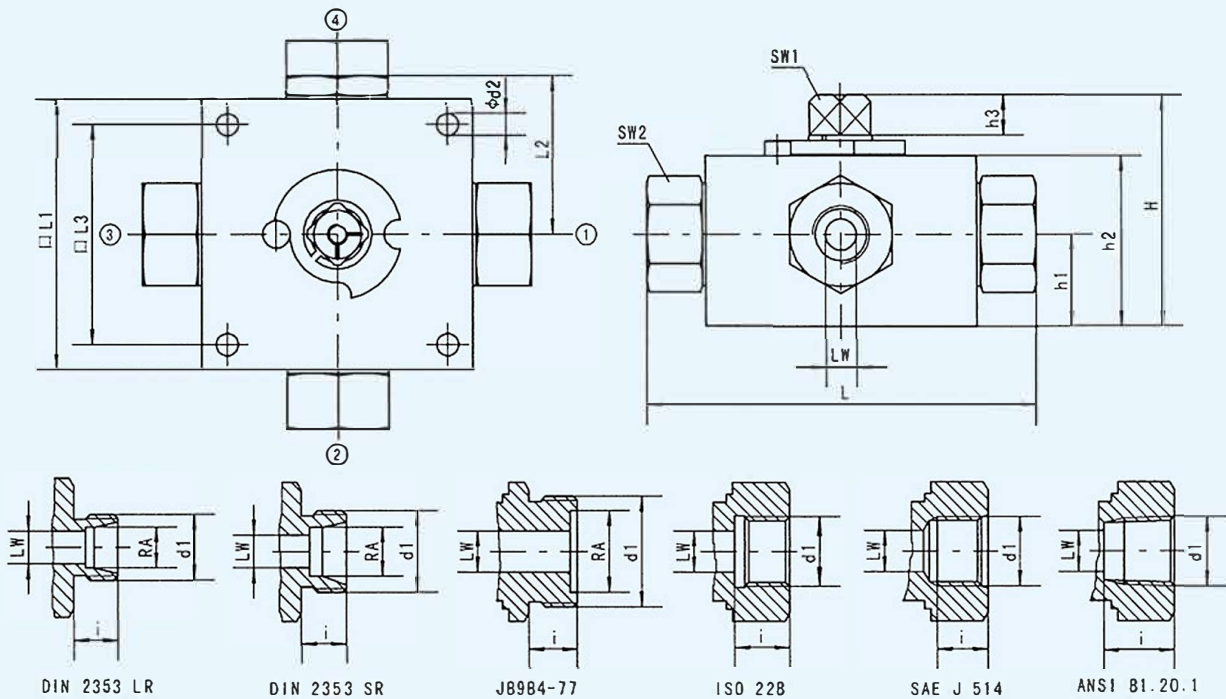

DIN 2353 / ISO 8434-1 Light series

Model	DN	PN	LW			RA	d1	d2	i	L	L1	L2	L3	H	h1	h2	h3	SW1	SW2
			L	T	X														
KH3/4-06LR	04	500	5	5	4.5	06	M12×1.5	6.5	10	105	70	42.5	55	57	22	40	11	12	24
KH3/4-08LR	06	500	5	5	4.5	08	M14×1.5	6.5	10	105	70	42.5	55	57	22	40	11	12	24
KH3/4-10LR	08	500	9	9	7	10	M16×1.5	6.5	11	114	80	46	65	68	27	50	12	14	30
KH3/4-12LR	10	500	9	9	7	12	M18×1.5	6.5	11	114	80	46	65	68	27	50	12	14	30
KH3/4-15LR	12	400	12	12	10	15	M22×1.5	9	12	136	100	56	80	78	31	60	12	14	36
KH3/4-18LR	12	400	12	12	10	18	M26×1.5	9	12	136	100	56	80	78	31	60	12	14	36
KH3/4-22LR	20	315	18	18	14	22	M30×2	9	14	143	100	58	85	93.5	36	73	14	17	46
KH3/4-28LR	25	315	23	23	17	28	M36×2	9	14	166	118	68.5	85	102.5	47.5	82	14	17	50
KH3/4-35LR	25/32	315	23	23	17	35	M45×2	9	16	170	118	68.5	85	102.5	47.5	82	14	17	50

DIN 2353 / ISO 8434-1 Heavy series

Model	DN	PN	LW			RA	d1	d2	i	L	L1	L2	L3	H	h1	h2	h3	SW1	SW2
			L	T	X														
KH3/4-08SR	04	500	5	5	4.5	08	M16×1.5	6.5	12	105	70	42.5	55	57	22	40	11	12	24
KH3/4-10SR	06	500	5	5	4.5	10	M18×1.5	6.5	12	105	70	42.5	55	57	22	40	11	12	24
KH3/4-12SR	08	500	9	9	7	12	M20×1.5	6.5	12	116	80	46	65	68	27	50	12	14	30
KH3/4-14SR	10	500	9	9	7	14	M22×1.5	6.5	14	120	80	46	65	68	27	50	12	14	30
KH3/4-16SR	12	400	12	12	10	16	M24×1.5	9	14	140	100	56	80	78	31	60	12	14	36
KH3/4-20SR	12	400	12	12	10	20	M30×2	9	16	144	100	56	80	78	31	60	12	14	36
KH3/4-25SR	20	315	18	18	14	25	M36×2	9	18	151	100	58	85	93.5	36	73	14	17	46
KH3/4-30SR	25	315	23	23	17	30	M42×2	9	20	176	118	68.5	85	102.5	47.5	82	14	17	50
KH3/4-38SR	25/32	315	23	23	17	38	M52×2	9	22	180	118	68.5	85	102.5	47.5	82	14	17	55

JB984-77 Male Metric Thread

Model	DN	PN	LW			RA	d1	d2	i	L	L1	L2	L3	H	h1	h2	h3	SW1	SW2
			L	T	X														
KH3/4-M12×1.25	04	500	5	5	4.5	8	M12×1.25	6.5	10	105	70	42.5	55	57	22	40	11	12	24
KH3/4-M16×1.5	06	500	5	5	4.5	11	M16×1.5	6.5	11	105	70	42.5	55	57	22	40	11	12	24
KH3/4-M22×1.5	08	500	9	9	7	16	M22×1.5	6.5	12	116	80	46	65	68	27	50	12	14	30
KH3/4-M27×1.5	10	500	9	9	7	20	M27×1.5	6.5	16	124	80	46	65	68	27	50	12	14	30
KH3/4-M30×1.5	12	400	12	12	10	24	M30×1.5	9	16	144	100	56	80	78	31	60	12	14	36
KH3/4-M36×2	20	315	18	18	14	30	M36×2	9	18	151	100	58	85	93.5	36	73	14	17	46
KH3/4-M42×2	25	315	23	23	17	35	M42×2	9	18	176	118	68.5	85	102.5	47.5	82	14	17	50

DIN ISO 228 Female Thread

Model	DN	PN	LW			RA	d1	d2	i	L	L1	L2	L3	H	h1	h2	h3	SW1	SW2
			L	T	X														
KH3/4-G1/8	04	500	5	5	4.5	-	G1/8	6.5	10	100	70	42.5	55	57	22	40	11	12	24
KH3/4-G1/4	06	500	5	5	4.5	-	G1/4	6.5	14	100	70	42.5	55	57	22	40	11	12	24
KH3/4-G3/8	10	500	9	9	7	-	G3/8	6.5	14	115	80	46	65	68	27	50	12	14	30
KH3/4-G1/2	12	400	12	12	10	-	G1/2	9	16	135	100	56	80	78	31	60	12	14	36
KH3/4-G3/4	20	315	18	18	14	-	G3/4	9	18	144	100	58	85	93.5	36	73	14	17	46
KH3/4-G1	25	315	23	23	17	-	G1	9	20.5	172	118	68.5	85	102.5	47.5	82	14	17	50
KH3/4-G1¼	25/32	315	23	23	17	-	G1¼	9	22	180	118	68.5	85	102.5	47.5	82	14	17	55

SAE J514/ISO/DIS11926-1 Female Thread

Model	DN	PN	LW			RA	d1	d2	i	L	L1	L2	L3	H	h1	h2	h3	SW1	SW2
			L	T	X														
KH3/4-SAE4	06	500	5	5	4.5	-	7/16-20UNF	6.5	12	100	70	42.5	55	57	22	40	11	12	24
KH3/4-SAE6	10	500	9	9	7	-	9/16-18UNF	6.5	13	115	80	46	65	68	27	50	12	14	30
KH3/4-SAE8	12	400	12	12	10	-	3/4-16UNF	9	15	135	100	56	80	78	31	60	12	14	36
KH3/4-SAE12	20	315	18	18	14	-	1½/16-12UN	9	20	144	100	58	85	93.5	36	73	14	17	46
KH3/4-SAE16	25	315	23	23	17	-	1½/16-12UN	9	20	172	118	68.5	85	102.5	47.5	82	14	17	50
KH3/4-SAE20	25/32	315	23	23	17	-	1½/8-12UN	9	20	180	118	68.5	85	102.5	47.5	82	14	17	55

ANSI B1.20.1 Npt Female Thread

Model	DN	PN	LW			RA	d1	d2	i	L	L1	L2	L3	H	h1	h2	h3	SW1	SW2
			L	T	X														
KH3/4-1/4NPT	06	500	5	5	4.5	-	1/4NPT	6.5	14	100	70	42.5	55	57	22	40	11	12	24
KH3/4-3/8NPT	10	500	9	9	7	-	3/8NPT	6.5	14	115	80	46	65	68	27	50	12	14	30
KH3/4-1/2NPT	12	400	12	12	10	-	1/2NPT	9	17	135	100	56	80	78	31	60	12	14	36
KH3/4-3/4NPT	20	315	18	18	14	-	3/4NPT	9	19	144	100	58	85	93.5	36	73	14	17	46
KH3/4-1NPT	25	315	23	23	17	-	1NPT	9	22.5	172	118	68.5	85	102.5	47.5	82	14	17	50
KH3/4-1¼NPT	25/32	315	23	23	17	-	1¼NPT	9	22.5	180	118	68.5	85	102.5	47.5	82	14	17	55

Note: The unit of DN is mm, and the unit of PN is bar.



How to order

KHP - 10 - 1 1 1 2 - 04 - Accessory

[1] [2] [3] [4] [5] [6] [7] [8]

[1] Model: KHP-Manifold type 2 way ball valve

[2] Nominal diameter: 06, 10, 16...mm

[3] Body & plug material: 1-Carbon steel
4-Stainless steel

[4] Ball & stem material: 1-Carbon steel; 4-Stainless steel

[5] Ball seat material: 1-POM 5-PEEK

[6] Plug & stem seal: 2-NBR 4-FKM

Remark: Product selection code 1112 is normal material, it could omit when place order.

[7] Levers type: 04-Zinc Alloy Bent levers

05-Steel Straight levers

06-Steel Bent levers

[8] valve can be offered with locking device or any other accessory like limit switches or actuators. Please check *Ball Valve Annex for more information

General dimensions

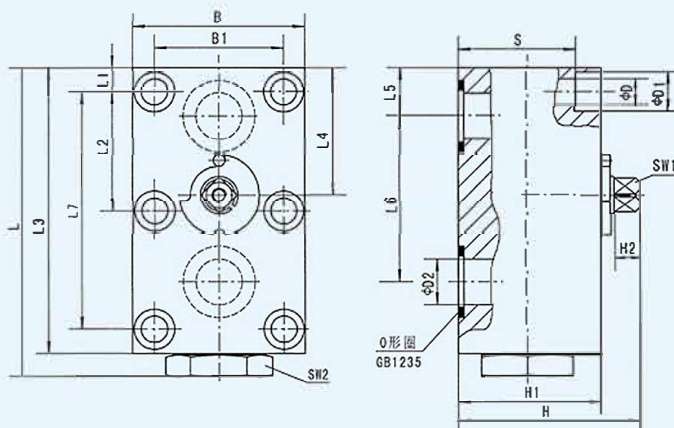

Model	DN	PN	L	L1	L2	L3	L4	L5	L6	L7	B
KHP-06	06	500	64	8.5	-	59	25	8.5	35	35	40
KHP-10	10	500	80	8	27.5	71	29.5	10.5	44	55	56
KHP-13	13	420	110	8.5	41.5	100	43.5	17	58	83	62
KHP-16	16	350	110	8.5	41.5	100	43.5	17	58	83	62
KHP-20	20	350	127	10	48.5	117	51	20	69	97	70
KHP-25	25	350	145	10	57.5	135	62	24	81	115	80
KHP-32	32	350	177	12	68	165	75	29	96	136	100
KHP-40	40	350	192	28.5	56	180	85.5	28.5	112	112	130
KHP-50	50	350	245	38	68	220	106	38	136	136	149

Model	B1	SW1	SW2	H	H1	H2	D	D1	D2	S	O-ring/GB1235
KHP-06	27	9	22	39	30	6	6.6	11	6	23	12×1.9
KHP-10	40	9	30	54.5	42	8	9	13.5	9.5	33	16×2.4
KHP-13	45	9	32	62	50	8	9	13.5	13	41	25×2.4
KHP-16	45	12	36	67.5	50	11	9	13.5	16	41	25×2.4
KHP-20	51	14	41	80	62	12	10.5	16.5	20	51	30×3.1
KHP-25	60	14	50	86	67	12	10.5	16.5	25	56	35×3.1
KHP-32	78	17	65	110	90	14	13	19	32	77	40×3.1
KHP-40	95	17	75	120	100	14	17.5	26	38	82	50×3.1
KHP-50	112	17	75	130	110	14	22	32	48	88	60×3.1

PN bar

Ordering and Usage Notes

The selection for ordering codes 3, 4, 5, and 6, which corresponds to the 1,1,1, and 2 configuration, is the default standard combination. No additional labeling is required unless there are specific requirements.



How to order

KHP3K - 10 - L - 1 1 1 2 - 04 - Accessory

[1] [2] [3] [4] [5] [6] [7] [8] [9]

- [1] Model: KHP3K-Manifold type 3 way ball valve
- [2] Nominal diameter: 06, 10, 16...mm
- [3] Porting pattern: L
- [4] Body & plug material: 1-Carbon steel
4-Stainless steel
- [5] Ball & stem material: 1-Carbon steel
4-Stainless steel
- [6] Ball seat material: 1-POM 5.PEE
- [7] Plug & stem seal: 2-NBR 4-FKM
- Remark): Product selection code 1112 is normal material, it could omit when place order.
- [8] Levers type: 04-Zinc Alloy Bent levers
05-Steel Straight levers
06-Steel Bent levers

[9] Valve can be offered with locking device or any other accessory like limit switches or actuators. Please check *Ball Valve Annex for more information

Porting patterns (See chart)

ATTENTION: Hydraulic oil can flow into the valve through port 1!

The valve can only be sealed under two specific situations:

- (1) Pressure at the closed port is zero:
- (2) Pressure at the closed port is lower than at the two open ports.

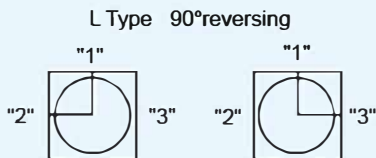

General dimensions

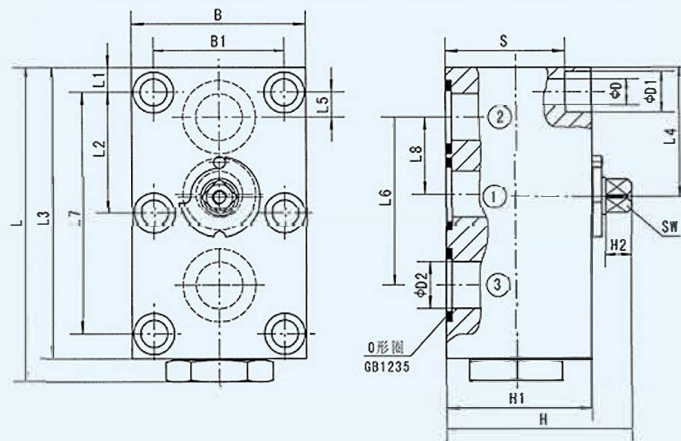

Model	DN	PN	L	L1	L2	L3	L4	L5	L6	L7	L8
KHP3K-06	6	500	64	8.5	-	59	25	0	35	35	17.5
KHP3K-10	10	350	80	8	27.5	71	29.5	2.5	44	55	19
KHP3K-16	16	350	110	8.5	41.5	100	43.5	8.5	58	83	26.5
KHP3K-20	20	350	127	10	48.5	117	51	10	69	97	32
KHP3K-25	25	350	145	10	57.5	135	62	14	81	115	38
KHP3K-32	32	350	177	12	68	165	75	17	96	136	46
KHP3K-40	40	350	192	28.5	56	180	85.5	0	112	112	56
KHP3K-50	50	350	245	38	68	220	106	0	136	136	68

Model	B	B1	H	H1	H2	D	D1	D2	S	SW	O-ring/GB1235
KHP3K-06	40	27	39	30	6	6.6	11	6	23	9	12×1.9
KHP3K-10	56	40	54.5	42	8	9	13.5	9.5	33	9	16×2.4
KHP3K-16	62	45	67.5	50	11	9	13.5	16	41	12	25×2.4
KHP3K-20	70	51	80	62	12	10.5	16.5	20	51	14	30×3.1
KHP3K-25	80	60	85	67	12	10.5	16.5	25	56	14	35×3.1
KHP3K-32	100	78	110	90	14	13	19	32	77	17	40×3.1
KHP3K-40	130	95	120	100	14	17.5	26	38	82	17	50×3.1
KHP3K-50	149	112	130	110	14	22	32	48	88	17	60×3.1

PN bar



Multiway Ball Valve For Manifold Mounting

How to order

KH3P - 16 - L - 1 1 1 2 - SB01 - 04 - Accessory
 [1] [2] [3] [4] [5] [6] [7] [8] [9] [10]



[1] Model: KH3P - 3-way ball valve for manifold mounting
 KH4P - 4-way ball valve for manifold mounting

[2] Nominal diameter: 06. 10. 16. 20mm

[3] Ball symbol: KH3P-L

KH3PT

KH4P-L

KH4P-T

KH4P-X

[4] Body & plug material: 1-Carbon steel

4-Stainless steel

[5] Ball & stem material: 1-Carbon steel

4-Stainless steel

[6] Ball seat material: 1-POM; 5-PEEK

[7] Body & connection seal: 2-NBR

4-FKM

Remark): Product selection codes 1112 is nonnal material, it could omit when place order.

[8] Porting pattern: See chart of porting pattern

[9] Levers type: 04-Zinc Alloy Bent levers

06-Steel Bent levers

[10] Valve can be offered with locking device or any other accessory like limit switches or actuators. Please check *Ball Valve Annex for more information

Porting patterns

3 way ball valve L type 90° operating angle, 45° closed

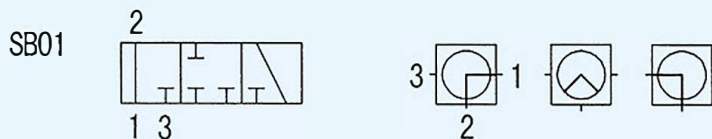

3 way ball valve T type 90° operating angle, 45° closed

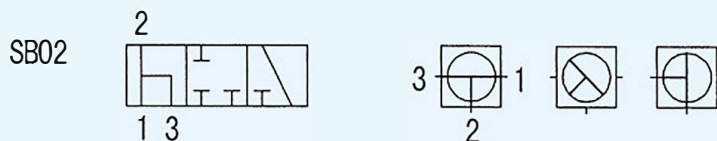



Multiway Ball Valve For Manifold Mounting

3 way ball valve T type 90° operating angle



3 way ball valve T type 180° operating angle

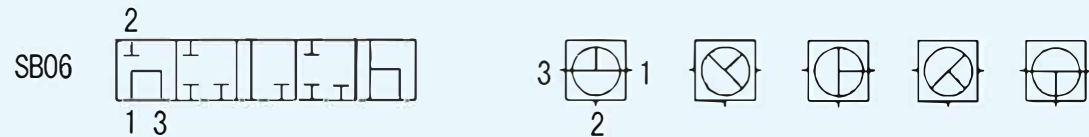
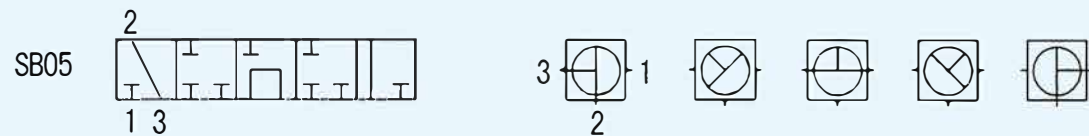
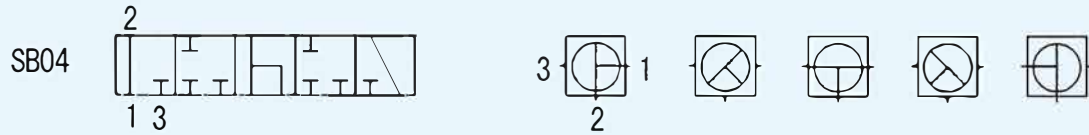

4 way ball valve L type 180° operating angle

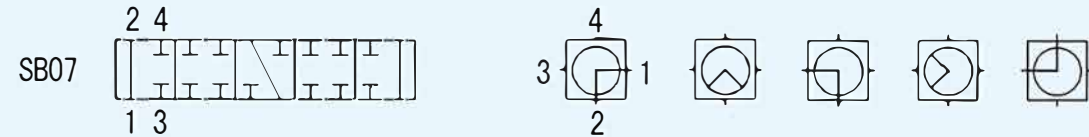

4 way ball valve T type 90° operating angle



4 way ball valve T type 180° operating angle

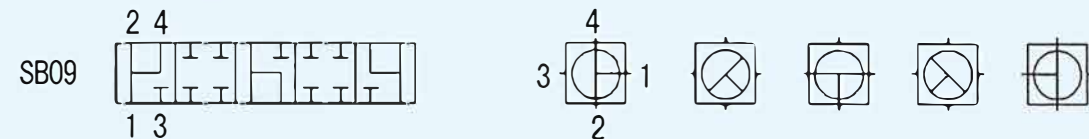

4 way ball valve X type 90° operating angle



This series of high pressure ball valve has three and four ways, you can find multiple control problems, and the best way to solve the fluid.



Multiway Ball Valve For Manifold Mounting

General dimensions

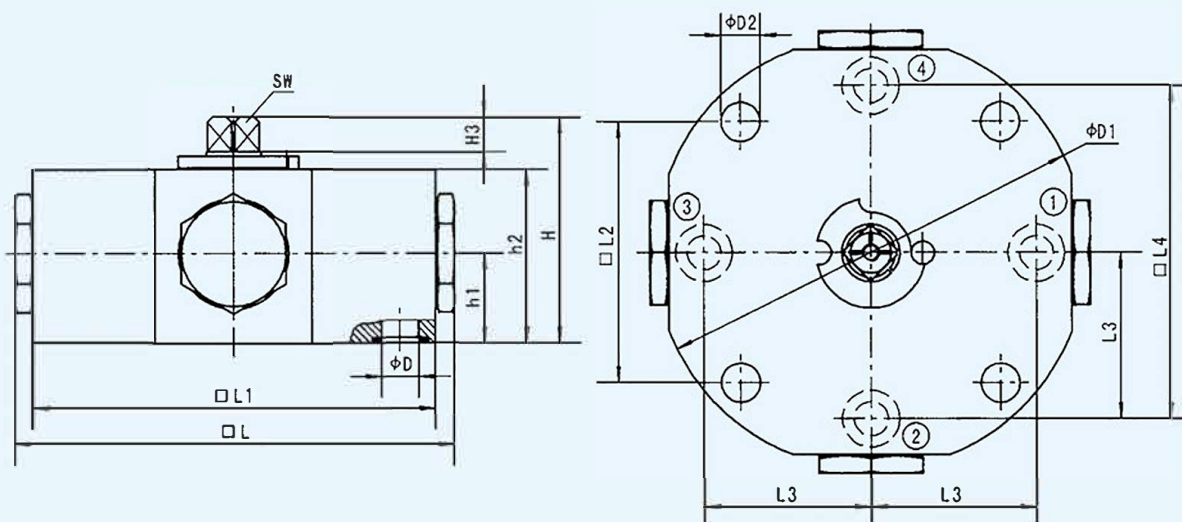

Model	DN	PN	LW			L	L1	L2	L3	L4	D	D1	D2	H	h1	h2	h3	SW
			L	T	X													
KH3P-06	06	400	5	5	4.5	102	90	70	34.3	-	6	-	6.5	57	22	40	11	12
KH3P-10	10	315	9	9	7	113	100	80	40.5	-	8	-	9	68	27	50	12	14
KH3P-16	16	315	12	12	10	153	140	90	57.7	-	13	150	13.5	78	31	60	12	14
KH3P-20	20	250	23	23	17	186	170	100	68.5	-	18	180	13.5	93.5	36	73	14	17

Model	DN	PN	LW			L	L1	L2	L3	L4	D	D1	D2	H	h1	h2	h3	SW
			L	T	X													
KH4P-06	06	400	5	5	4.5	102	90	70	-	68.6	6	-	6.5	57	22	40	11	12
KH4P-10	10	315	9	9	7	113	100	80	-	81	8	-	9	68	27	50	12	14
KH4P-16	16	315	12	12	10	153	140	90	-	115.4	13	150	13.5	78	31	60	12	14
KH4P-20	20	250	23	23	17	186	170	100	-	137	18	180	13.5	93.5	36	73	14	17

Note: The unit of DN is mm, and the unit of PN is bar.

With SAE Connection



How to order

KHB	-	20	-	F3	-	1	1	1	2	-	1	-	Accessory
[1]		[2]		[3]		[4]	[5]	[6]	[7]		[8]		[9]

- [1] Model: KHB-Square body DN16-25
KHM-Eight-Square Body DN32-50
- [2] Nominal diameter: 16、20、50mm
- [3] Flange code: F 3-SAEJ518C3000psi (21MPa)
F6-SAEJ518C6000psi (42MPa)
- [4] Body and Connection material: 1-Carbon steel
4-Stainless steel
- [5] Ball & stem material: 1-Carbon steel:
4-Stainless steel
- [6] Ball seat material: 1-POM; 4-PTFE; 5-PEEK
- [7] Connection & stem seal: 2-NBR; 4-FKM
- [8] SAE C flange material: 1-Carbon steel
- [9] Valve can be offered with locking device or any other accessory like limit switches or actuators. Please check *Ball Valve Annex for more information

General dimensions

KHB-F3/F6

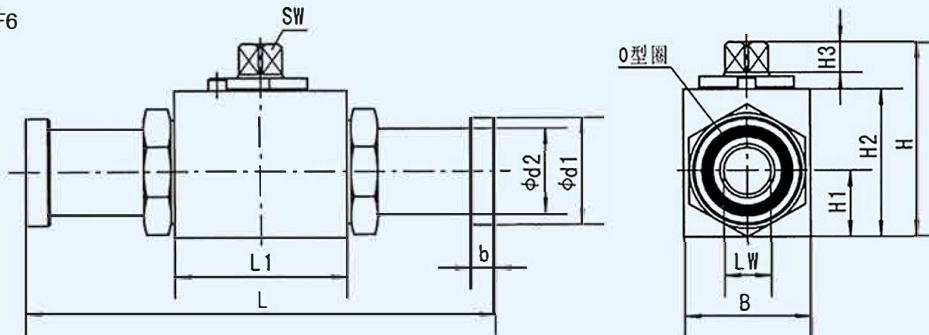

KHB-F3																
Model	SAE Size	DN	PN	LW	L	L1	H	H1	H2	H3	B	b	d1	d2	SW	O-ring
KHB-13-F3	1/2"	13	350	13	151	48	52.5	17	40	8	35	6.8	30.2	24	9	18.64x3.53
KHB-16-F3	3/4"	16	350	15	170	47	63.5	19	46	11	38	6.8	38.1	31.5	12	24.99x3.53
KHB-20-F3	3/4"	20	350	19	170	60	75	24	57	12	48	6.8	38.1	31.5	14	24.99x3.53
KHB-25-F3	1"	25	315	25	176.5	65	82	28.5	64	12	57	8	44.45	38	14	32.92x3.53

KHB-F6																
型号	SAE Size	DN	PN	LW	L	L1	H	H1	H2	H3	B	b	d1	d2	SW	O-ring
KHB-13-F6	1/2"	13	420	13	151	48	52.5	17	40	8	35	7.9	31.8	24	9	18.64x3.53
KHB-16-F6	3/4"	16	400	15	170	47	63.5	19	46	11	38	8.8	41.3	32	12	24.99x3.53
KHB-20-F6	3/4"	20	350	19	170	60	75	24	57	12	48	8.8	41.3	32	14	24.99x3.53
KHB-25-F6	1"	25	350	25	198	65	82	28.5	64	12	57	9.5	47.6	38	14	32.92x3.53



KHM-F3/F6

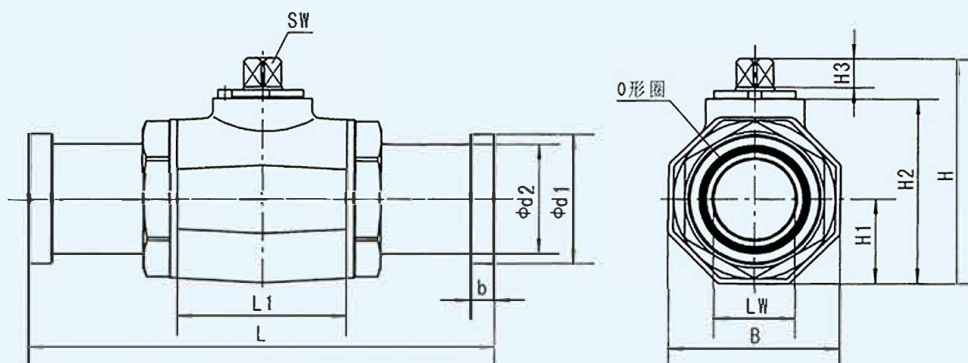

KHM-F3

Model	SAE Size	DN	PN	LW	L	L1	H	H1	H2	H3	B	b	d1	d2	SW	O-ring
KHM-32-F3	1/4"	32	275	30	191	84	108	41	87.5	14	82	8	50.8	43	17	37.69x3.53
KHM-40-F3	1/2"	40	210	38	231	91	119.5	46.5	99	14	93	8	60.35	50	17	47.22x3.53
KHM-50-F3	2"	50	210	48	234	100	135.5	55	115	14	110	9.6	71.4	62	17	56.74x3.53

KHM-F6

Model	SAE Size	DN	PN	LW	L	L1	H	H1	H2	H3	B	b	d1	d2	SW	O-ring
KHM-32-F6	1/4"	32	350	30	223	84	108	41	87.5	14	82	10.3	54	44	17	37.69x3.53
KHM-40-F6	1/2"	40	350	38	281	91	119.5	46.5	99	14	93	12.6	63.5	51	17	47.22x3.53
KHM-50-F6	2"	50	350	48	315	100	135.5	55	115	14	110	12.6	79.4	67	17	56.74x3.53

Ordering and Usage Notes

1. The Product selection codes 4, 5, 6, and 7, which corresponds to the 1,1,1, and 2 configuration, is the default standard combination. No additional labeling is required unless there are specific requirements.
2. If SAE flange is required there is an additional cost
3. Supply with a 06-Steel Bent levers



How to order

KHSAE	210	-	32	-	2	1	2	A
[1]	[2]		[3]		[4]	[5]	[6]	[7]

[1] Model: KHSAE-Fixed flange ball valve

[2] Pressure setting: 210, 420bar

[3] Nominal diameter: 15, 20...mm

[4] Body and Connection material: 2-Carbon steel

[5] Ball & stem material: 1-Carbon steel

4-Stainless steel

[6] Ball seat material: 2-POM; 4-PTFE; 5-PEEK

[7] Connection & stem seal: A-NBR; 8-FPM; 8-FKM

Remark): Product selection codes 212A is normal material, it could on it when place order.

General dimensions

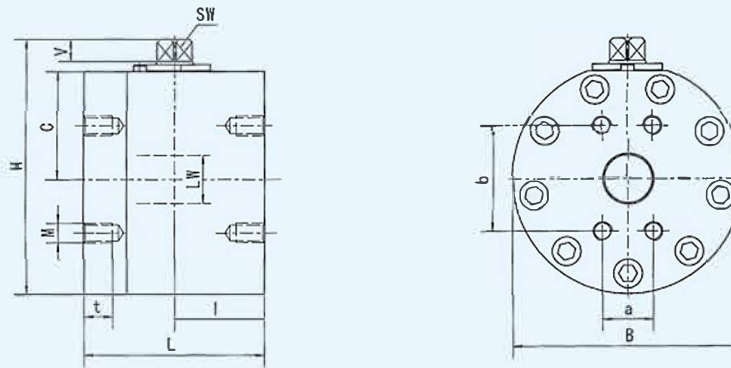

SAE J 518 C 21MPa/3000psi

Model	DN	PN	LW	L	I	B	C	H	V	SW	a	b	M	t
KHSAE210-15	15	350	15	75	35	77	31	86.5	11	12	17.5	38.1	M8	16
KHSAE210-20	20	350	20	80	35	97	37.5	104	12	14	22.2	47.6	M10	18
KHSAE210-25	25	320	25	88	38	117	40	116.5	12	14	26.2	52.4	M10	18
KHSAE210-32-M10	32	210	30	100	47	145	68	161	14	17	30.2	58.7	M10	20
KHSAE210-32-M12	32	210	30	100	47	145	68	161	14	17	30.2	58.7	M12	20
KHSAE210-40	40	210	38	110	54	165	78	180	14	17	35.7	69.8	M12	20
KHSAE210-50	50	210	48	116	58	197	94	213	14	17	42.9	77.8	M12	20
KHSAE210-65	65	175	60	150	75	197	92	211	14	17	50.8	88.9	M12	20
KHSAE210-80	80	160	70	140	70	207	98	232	24	20	61.9	106.4	M16	24
KHSAE210-100	100	35	95	170	85	257	121	282.5	26	24	77.8	130.2	M16	24
KHSAE210-125	125	35	118	210	105	295	140	330.5	36	36	92.1	152.4	M16	30

SAE J 518 C 42MPa/3000psi

Model	DN	PN	LW	L	I	B	C	H	V	SW	a	b	M	t
KHSAE420-15	15	420	15	75	35	77	31	86.5	11	12	18.2	40.5	M8	16
KHSAE420-20	20	420	20	80	35	97	37.5	104	12	14	23.8	50.8	M10	18
KHSAE420-25	25	420	25	88	38	117	40	116.5	12	14	27.8	57.2	M12	20
KHSAE420-32	32	400	30	100	47	145	68	161	14	17	31.8	66.7	M14	22
KHSAE420-40	40	400	38	110	54	165	78	180	14	17	36.5	79.4	M16	24
KHSAE420-50	50	400	48	116	58	197	94	213	14	17	44.5	96.8	M20	28
KHSAE420-65	65	350	60	170	85	217	100	229	14	17	58.7	123.8	M24	41
KHSAE420-80	80	350	70	170	85	256	120	278.5	24	20	71.4	152.4	M30	47

Ordering and Usage Notes

1. Lever must be fixed centrally during operation. In case of vibration the lever may otherwise operate the valve by itself.
2. Supply with a 06-Steel Bent levers
3. With handle when leaving the factory.



Introduction

The KHZ two-way series high-pressure ball valve interface is designed according to the SAE flange standard. It can be installed between the hydraulic block with a flange on one side and a hydraulic pipe on the other side. It is also suitable for connecting different types of pipes. When using materials of various compositions, it can be applied to a wide range of scenarios.

How to order

KHZ - DN13 - SAE420 - 1 1 2 A - 04
 [1] [2] [3] [4] [5] [6] [7] [8]

[1] Model: KHZ- KHZ series SAE flange ball valve

[2] Nominal diameter: DN13~DN50

[3] Connection standard and pressure setting

[4] Body and Connection material: 1-Carbon steel

4-Stainless steel

[5] Ball & stem material: 1-Carbon steel; 4-Stainless steel

[6] Ball seat material: 2-POM; 5-PEEK

[7] Body connection & connection seal:A-NBR; 8-FKM

(Remark):Product selection codes 112A is nonnal material,it could omit when place order.

[8] 8.Levers type: 04-Zinc Alloy Bent levers

05-Steel Straight levers

06-Steel Bent levers

General dimensions

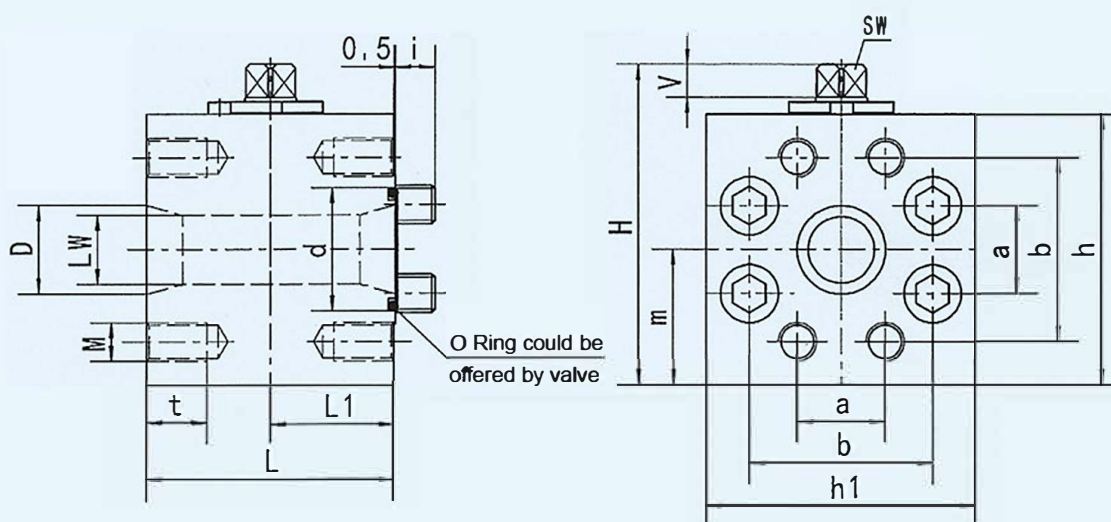

KHZ-※-SAE210

Model	DN	PN	LW	D	d	L	L1	H	h	h1
KHZ-DN13-SAE210	13	350	13	13	25.5	68	34	70	58	58
KHZ-DN20-SAE210	20	350	20	20	31.9	70	35	93	75	75
KHZ-DN25-SAE210	25	320	22	24	39.8	78	39	100	82	82
KHZ-DN32-SAE210	32	280	25	32	44.5	90	45	116	98	98
KHZ-DN40-SAE210	40	210	30	38	54.1	99	49.5	136.5	116	116
KHZ-DN50-SAE210	50	210	38	49	63.6	120	60	158	138	138



Model	a	b	M	m	t	i	V	SW	Nut
KHZ-DN13-SAE210	17.5	38.1	M8	30	15	11	8	9	M8×70
KHZ-DN20-SAE210	22.2	47.6	M10	37.5	17	12.5	12	14	M10×70
KHZ-DN25-SAE210	26.2	52.4	M10	41	17	13	12	14	M10×80
KHZ-DN32-SAE210	30.2	58.7	M10	49	21	10.5	12	14	M10×90
KHZ-DN40-SAE210	35.7	69.8	M12	58	21	13.5	14	17	M12×100
KHZ-DN50-SAE210	42.9	77.8	M12	69	21	12.5	14	17	M12×130

KHZ-※-SAE420

Model	DN	PN	LW	D	d	L	L1	H	h	h1
KHZ-DN13-SAE420	13	420	13	13	25.5	68	34	70	58	58
KHZ-DN20-SAE420	20	420	20	20	31.9	70	35	93	75	75
KHZ-DN25-SAE420	25	420	25	25	39.8	78	39	100	82	82
KHZ-DN32-SAE420-M12	32	350	32	32	44.5	90	45	116	98	98
KHZ-DN32-SAE420	32	350	25	32	44.5	90	45	116	98	98
KHZ-DN40-SAE420	40	350	30	38	54.1	99	49.5	136.5	116	116
KHZ-DN50-SAE420	50	350	38	49	63.6	120	60	158	138	138

Model	a	b	M	m	t	i	V	SW	Nut
KHZ-DN13-SAE420	18.2	40.5	M8	29	15	11	8	9	M8×70
KHZ-DN20-SAE420	23.8	50.8	M10	37.5	17	12	12	14	M10×80
KHZ-DN25-SAE420	27.8	57.2	M12	42	21	14.5	12	14	M12×80
KHZ-DN32-SAE420-M12	31.8	66.6	M12	49	21	14.5	12	14	M12×90
KHZ-DN32-SAE420	31.8	66.6	M14	49	22	14.5	12	14	M14×90
KHZ-DN40-SAE420	36.5	79.4	M16	58	26	18	14	17	M16×100
KHZ-DN50-SAE420	44.5	96.8	M20	69	34	31	14	17	M20×130

Note: The unit of DN is mm, and the unit of PN is bar.



With SAE Flange (Manifold Mounting)

How to order

KH2K - DN40 - SAE420 - 1 1 2 A - 06 - Accessory

[1] [2] [3] [4] [5] [6] [7] [8] [9]

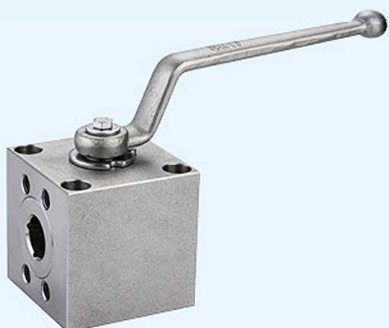

[1] Model: KH2K

[2] Nominal diameter: DN13~DN50

[3] Connection standard

[4] 4.Body and Flange material: 1-Carbon steel

[5] Ball & stem material: 1-Carbon steel;
4-Stainless steel

[6] Ball seat material: 2-POM 5-PEEK

[7] Body Connection: A-NBR: 8-FKM

Remark): Product selection codes 112A is normal material, it could omit when place order.

[8] Levers type: 04-Zinc Alloy Bent levers

05-Steel Straight levers

06-Steel Bent levers

[9] valve can be offered with locking device or any other accessory like limit switches or actuators. Please check *Ball Valve Annex for more information

General dimensions

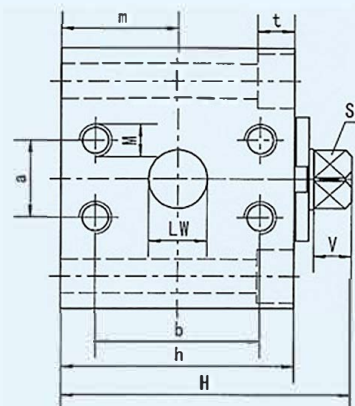
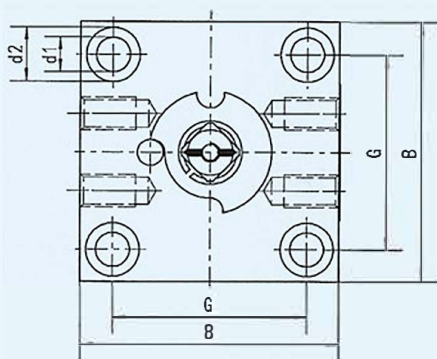

Model	DN	PN	LW	B	H	h	m	SW
KH2K-DN13-SAE420	13	420	13	60	68	56	28	9
KH2K-DN20-SAE420	20	420	20	80	93	75	37.5	14
KH2K-DN25-SAE420	25	420	25	94	100	82	42	14
KH2K-DN32-SAE420	32	350	30	100	120.5	100	50.5	17
KH2K-DN40-SAE420	40	350	36	110	132.5	112	56	17
KH2K-DN50-SAE420	50	350	46	135	155.5	135	67.5	17

Model	v	a	b	M	G	d1	d2	t
KH2K-DN13-SAE420	7.5	18.2	40.5	M8	43	8.5	13.5	9
KH2K-DN20-SAE420	12	23.8	50.8	M10	60	10.5	16.5	11
KH2K-DN25-SAE420	12	27.8	57.2	M12	70	10.5	16.5	11
KH2K-DN32-SAE420	14	31.8	66.6	M14	76	13	19	13
KH2K-DN40-SAE420	14	36.5	79.4	M16	84	13	19	13
KH2K-DN50-SAE420	14	44.5	96.8	M20	108	13	19	13

Note: The unit of DN is mm, and the unit of PN is bar.



With SAE Connection

How to order



KH3K - DN13 - SAE420 - 1 1 2 A - L - 06 - Accessory

[1] [2] [3] [4] [5] [6] [7] [8] [9]

- [1] Model: KH3K- KH3K series SAE flange 3 way ball valve
- [2] Nominal diameter: DN13-50mm
- [3] Connection standard
- [4] Body and connection material: 1-Carbon steel
4-Stainless steel
- [5] Ball & stem material: 1-Carbon steel:
4-Stainless steel
- [6] Ball seat material: 2-POM 5-PEEK
- [7] Block and connection material: A-NBR: 8-FPM
- [8] Porting pattern: L type
- [9] Levers type: 04-Zinc Alloy Bent levers
05-Steel Straight levers
06-Steel Bent levers
- [10] Valve can be offered with locking device or any other accessory like limit switches or actuators. Please check "Ball Valve Annex for more information

Remark): Product selection codes 112A is normal material, it could omit when place order.

Porting patterns (See chart)

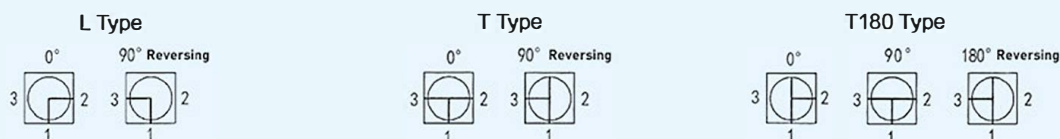

General dimensions

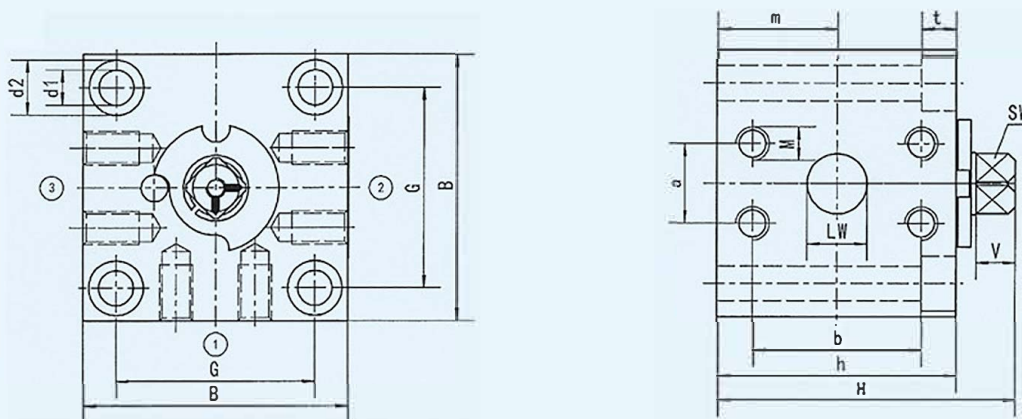

Model	DN	PN	LW	B	H	h	m	SW
KH3K-DN13-SAE420	13	420	13	60	68	56	28	9
KH3K-DN20-SAE420	20	420	20	80	93	75	37.5	14
KH3K-DN25-SAE420	25	420	25	94	100	82	42	14
KH3K-DN32-SAE420	32	350	30	100	120.5	100	50.5	17
KH3K-DN40-SAE420	40	350	36	110	132.5	112	56	17
KH3K-DN50-SAE420	50	350	46	135	155.5	135	67.5	17

Model	v	a	b	M	G	d1	d2	t
KH3K-DN13-SAE420	8	18.2	40.5	M8	43	8.5	13.5	9
KH3K-DN20-SAE420	12	23.8	50.8	M10	60	10.5	16.5	11
KH3K-DN25-SAE420	12	27.8	57.2	M12	70	10.5	16.5	11
KH3K-DN32-SAE420	14	31.8	66.6	M14	76	13	19	13
KH3K-DN40-SAE420	14	36.5	79.4	M16	84	13	19	13
KH3K-DN50-SAE420	14	44.5	96.8	M20	108	13	19	13

Note: The unit of DN is mm, and the unit of PN is bar.



With SAE Connection

How to order

BKH-SAE	210	-	13	-	1	1	2	3	-	04	-	Accessory
[1]	[2]		[3]		[4]	[5]	[6]	[7]		[8]		[9]

[1] Model: BKH-SAE-Square Body

MKH-SAE-Eight-Square Body

[2] Pressure setting: 210bar, 420bar

[3] Nominal diameter: 13, 20...mm

[4] Body and Connection material: 1-Carbon steel (BKH-SAE)

2-Carbon steel (MKH-SAE)

[5] Ball stem material: 1-Carbon steel

4-Stainless steel

[6] Ball seat material: 2-POM; 4-PTFE; 5-PEEK

[7] Connection stem seal: 3-NBR; 5-FKM

[8] Levers type: 04-Zinc Alloy Bent levers

05-Steel Straight levers

06-Steel Bent levers

Remark): Product selection codes is normal material, it could omit when place order.

BKH-SAE-1123

MKH-SAE-2123

[9] valve can be offered with locking device or any other accessory like limit switches or actuators. Please check *Ball Valve Annex for more information



General dimensions

BKH-SAE

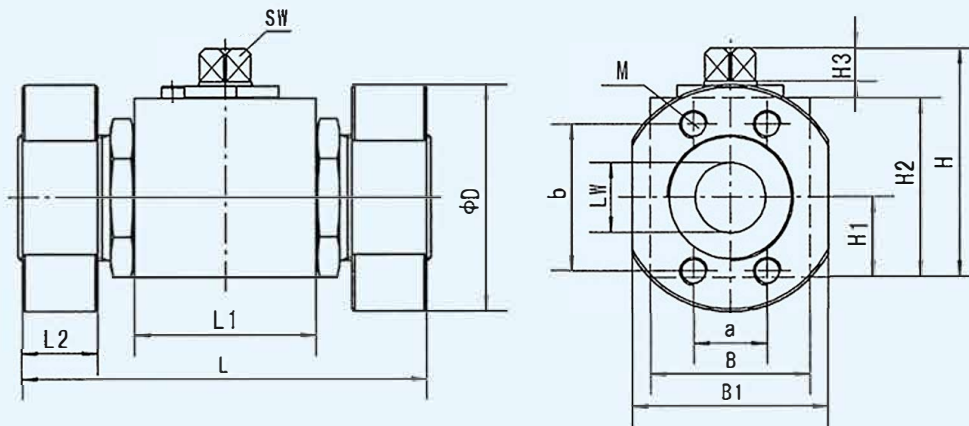

210bar(3000psi)

Model	PN	LW	L	L1	L2	D	B	B1	H	H1	H2	H3	a	b	M	SW
BKH-SAE210-13	350	13	120	48	16	57	35	46	52.5	17	40	8	17.5	38.1	M8	9
BKH-SAE210-20	315	20	136	60	18	70	48	52	75	24	57	12	22.2	47.6	M10	14
BKH-SAE210-25	315	25	148	65	19	77	57	62	82	28.5	64	12	26.2	52.4	M10	14

420bar(6000psi)

Model	PN	LW	L	L1	L2	D	B	B1	H	H1	H2	H3	a	b	M	SW
BKH-SAE420-13	420	13	120	48	22	61	35	48	52.5	17	40	8	18.2	40.5	M8	9
BKH-SAE420-20	315	20	136	60	23	76	48	60	75	24	57	12	23.8	50.8	M10	14
BKH-SAE420-25	315	25	148	65	27	86	57	70	82	28.5	64	12	27.8	57.2	M12	14

With SAE Connection

MKH-SAE

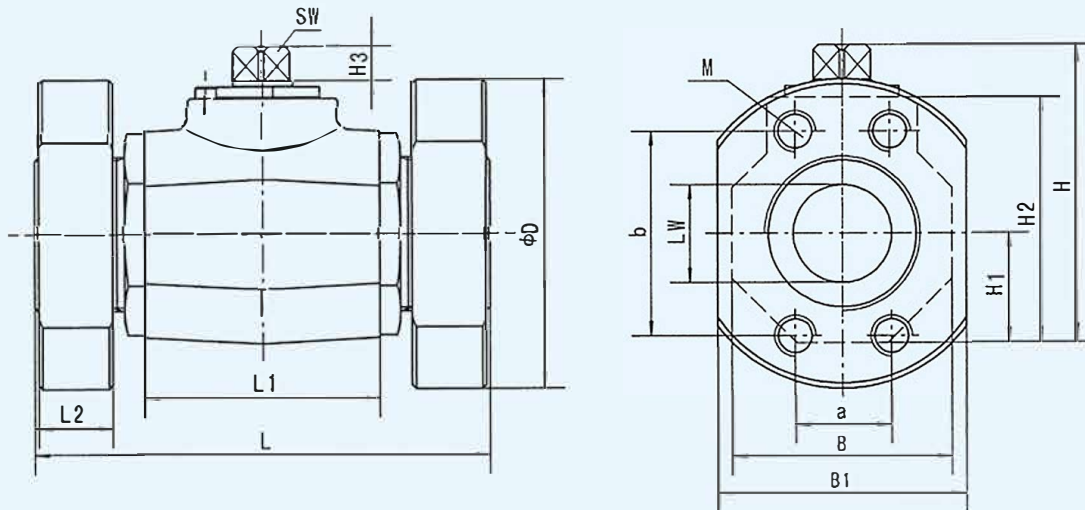

210bar(3000psi)																
Model	PN	LW	L	L1	L2	D	B	B1	H	H1	H2	H3	a	b	M	SW
MKH-SAE210-32-M10	210	30	172	84	21	87	82	74	108	41	87.5	14	30.2	58.7	M10	17
MKH-SAE210-32-M12	210	30	172	84	21	87	82	74	108	41	87.5	14	30.2	58.7	M12	17
MKH-SAE210-40	210	38	177	91	24	103	93	86	119.5	46.5	99	14	35.7	69.8	M12	17
MKH-SAE210-50	210	48	196	100	25	117	110	98	135.5	55	115	14	42.9	77.8	M12	17
MKH-SAE210-50/65	210	48	196	100	25	128	110	114	135.5	55	115	14	50.8	88.9	M12	17
MKH-SAE210-65	175	60	260	110	25	128	φ137	114	154	68.5	133.5	14	50.8	88.9	M12	17

420bar(6000psi)																
Model	PN	LW	L	L1	L2	D	B	B1	H	H1	H2	H3	a	b	M	SW
MKH-SAE420-32	350	30	172	84	32	103	82	78	108	41	87.5	14	31.8	66.7	M14	17
MKH-SAE420-40	350	38	177	91	32	120	93	96	119.5	46.5	99	14	36.5	79.4	M16	17
MKH-SAE420-50	350	48	196	100	34	145	110	114	135.5	55	115	14	44.5	96.8	M20	17
MKH-SAE420-65	315	60	280	110	45	192	φ145	150	158	72.5	137.5	14	58.7	123.8	M24	17

Ordering and Usage Notes

- MKH-SAE210-32-M12 is not recommended unless there are special needs. It is recommended to purchase MKH-SAE210-32-M10 for the same size, which is more reliable.
- DN13~DN25 supply with 04-Zinc Alloy Bent levers. DN32~DN60 supply with 06-Steel Bent lever. DN65-100 supply with 07 high pressure ball valve lever. Check annex for more information.



One End With SAE Split Flange Adapter, Other End With SAE Adapter Metric

How to order



BKH	-	SAE	210	-	25	-	D/S	-	1	1	2	3	-	Accessory
[1]		[2]	[3]		[4]		[5]		[6]	[7]	[8]	[9]		[10]

- [1] Model: BKH-Square body
MKH-Eight Square Body
 - [2] SAE: Flange connection
 - [3] Pressure setting: 210bar, 420bar
 - [4] Nominal diameter: 13、20、25、32、40、50mm
 - [5] Ball valve with SAE split flange adapter / adapter
 - [6] Body, connection and flange material: 1-Carbon steel (BKH)
4-Carbon steel (MKH)
 - [7] Ball & stem material: 1-Carbon steel:
4-Stainless steel
 - [8] Ball seat material: 2-POM; 4-PTFE; 5-PEEK
 - [9] Body Connection & connection seal: 3-NBR; 5-FKM
- Remark): Product selection codes is nonnal material, it could omit when place order.
- BKH-SAE※-※-D/S-1123
MKH-SAE※-※-D/S-2123
- [10] Valve can be offered with locking device or any other accessory like limit switches or actuators. Please check *Ball Valve Annex for more information

General dimensions

BKH-SAE※-※-D/S

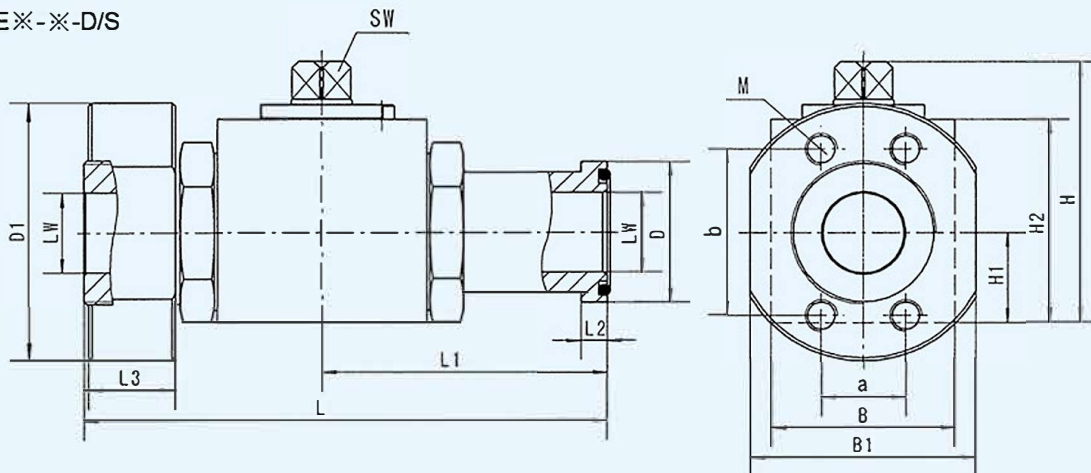

210bar(3000psi)																	
Model	DN	PN	L	L1	L2	L3	D	D1	a	b	M	B	B1	H	H1	H2	SW
BKH-SAE210-13-D/S	13	350	135.5	75.5	6.8	16	30.2	57	17.5	38.1	M8	35	46	52.5	17	40	9
BKH-SAE210-20-D/S	20	315	149	81	6.8	18	38.1	70	22.2	47.6	M10	48	52	75	24	57	14
BKH-SAE210-25-D/S	25	315	163	89	8.1	19	44.4	77	26.2	52.4	M10	57	62	82	28.5	64	14

420bar(6000psi)																	
Model	DN	PN	L	L1	L2	L3	D	D1	a	b	M	B	B1	H	H1	H2	SW
BKH-SAE420-13-D/S	13	420	135.5	75.5	7.9	22	31.8	61	18.2	40.5	M8	35	48	52.5	17	40	9
BKH-SAE420-20-D/S	20	315	155	87	8.9	23	41.3	76	23.8	50.8	M10	48	60	75	24	57	14
BKH-SAE420-25-D/S	25	315	173	99	9.6	27	47.6	86	27.8	57.2	M12	57	70	82	28.5	64	14

Note: The unit of DN is mm, and the unit of PN is bar.

One End With SAE Split Flange Adapter, Other End With SAE Adapter Metric

BKH-SAE×-×-D/S

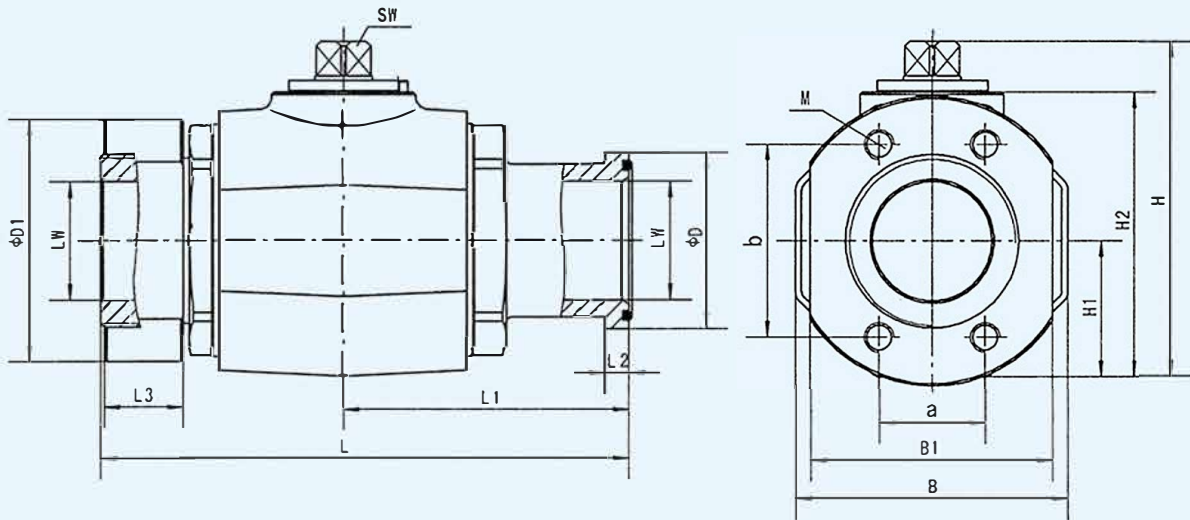

210bar(3000psi)																	
Model	DN	PN	L	L1	L2	L3	D	D1	a	b	M	B	B1	H	H1	H2	SW
MKH-SAE210-32-D/S-M10	32	210	181.5	95.5	8.1	21	50.8	87	30.2	58.7	M10	82	74	108	41	87.5	17
MKH-SAE210-32-D/S-M12	32	210	181.5	95.5	8.1	21	50.8	87	30.2	58.7	M12	82	74	108	41	87.5	17
MKH-SAE210-40-D/S	40	210	204	115.5	8.1	24	60.3	103	35.7	69.8	M12	93	86	119.5	46.5	99	17
MKH-SAE210-50-D/S	50	210	214	116	9.6	25	71.4	117	42.9	77.8	M12	110	98	135.5	55	115	17

420bar(6000psi)																	
Model	DN	PN	L	L1	L2	L3	D	D1	a	b	M	B	B1	H	H1	H2	SW
MKH-SAE420-32-D/S	32	350	197.5	111.5	10.4	32	54	103	31.8	66.7	M14	82	78	108	41	87.5	17
MKH-SAE420-40-D/S	40	350	229	140.5	12.7	32	63.5	120	36.5	79.4	M16	93	96	119.5	46.5	99	17
MKH-SAE420-50-D/S	50	350	256	158	12.7	34	79.4	145	44.5	96.8	M20	110	114	135.5	55	115	17

Ordering and Usage Notes

1. MKH-SAE210-32-D/S-M12 is not recommended unless there are special needs. It is recommended to purchase MKH-SAE210-32-D/S-M10 for the same size, which is more reliable.
2. DN13~DN25 supply with 04-Zinc Alloy Bent levers. DN32~DN50 supply with 06-Steel Bent lever. Check annex for more information.



One End With SAE Long Split Flange Adapter, Other End With SAE Adapter Metric

How to order



BKH	-	SAE	210	-	25	-	D/S	-	Lu	-	1	2	3
[1]		[2]	[3]		[4]		[5]		[6]		[7]	[8]	[9] [10]

- [1] Model: BKH-Square body
MKH-Eight Square Body
 - [2] SAE: Flange connection
 - [3] Pressure setting: 210bar, 420bar
 - [4] Nominal diameter: 13、20、25、32、40、50mm
 - [5] Ball valve with SAE long split flange adapter / adapter
 - [6] Joint type: LU-long joint
 - [7] Body, Adapter and Flange material: 1-Carbon steel (BKH)
2-Carbon steel (MKH)
 - [8] Ball & stem material: 1-Carbon steel:
4-Stainless steel
 - [9] Ball seat material: 2-POM; 5-PEEK
 - [10] Body & connection seal: 3-NBR; 5-FKM
- Remark): Product selection codes is normal material, it could omit when place order.
- BKH-SAE*-*-D/S-Lu-1123
MKH-SAE*-*-D/S-Lu-2123

General dimensions

BKH-SAE*-*-D/S-Lu

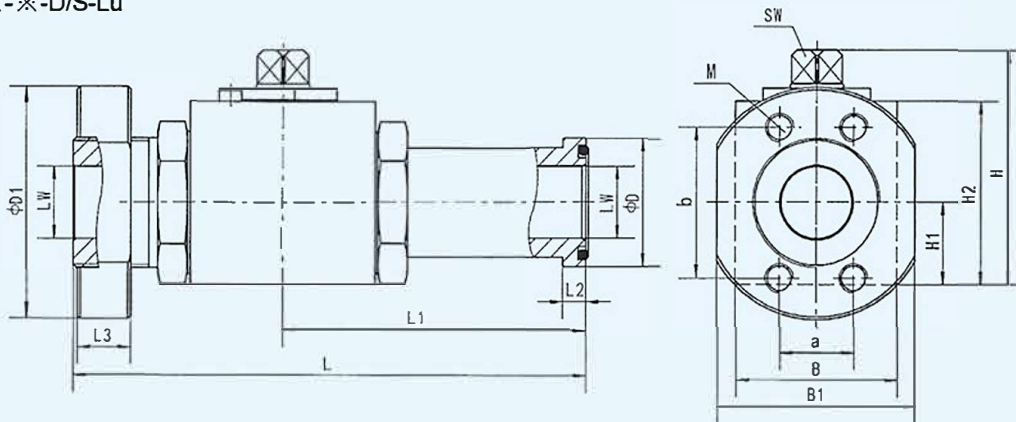

210bar(3000psi)																	
Model	DN	PN	L	L1	L2	L3	D	D1	a	b	M	B	B1	H	H1	H2	SW
BKH-SAE210-13-D/S-Lu	13	210	145	86	6.8	16	30.2	57	17.5	38.1	M8	35	46	52.5	17	40	9
BKH-SAE210-20-D/S-Lu	20	210	168	100	6.8	18	38.1	70	22.2	47.6	M10	48	52	75	24	57	14
BKH-SAE210-25-D/S-Lu	25	210	181.5	107.5	8.1	19	44.4	77	26.2	52.4	M10	57	62	82	28.5	64	14

420bar(6000psi)																	
Model	DN	PN	L	L1	L2	L3	D	D1	a	b	M	B	B1	H	H1	H2	SW
BKH-SAE420-13-D/S-Lu	13	420	150	90	7.9	22	31.8	61	18.2	40.5	M8	35	48	52.5	17	40	9
BKH-SAE420-20-D/S-Lu	20	315	168	100	8.9	23	41.3	76	23.8	50.8	M10	48	60	75	24	57	14
BKH-SAE420-25-D/S-Lu	25	315	199	125	9.6	27	47.6	86	27.8	57.2	M12	57	70	82	28.5	64	14

One End With SAE Long Split Flange Adapter, Other End With SAE Adapter Metric

MKH-SAE※-※-D/S-Lu

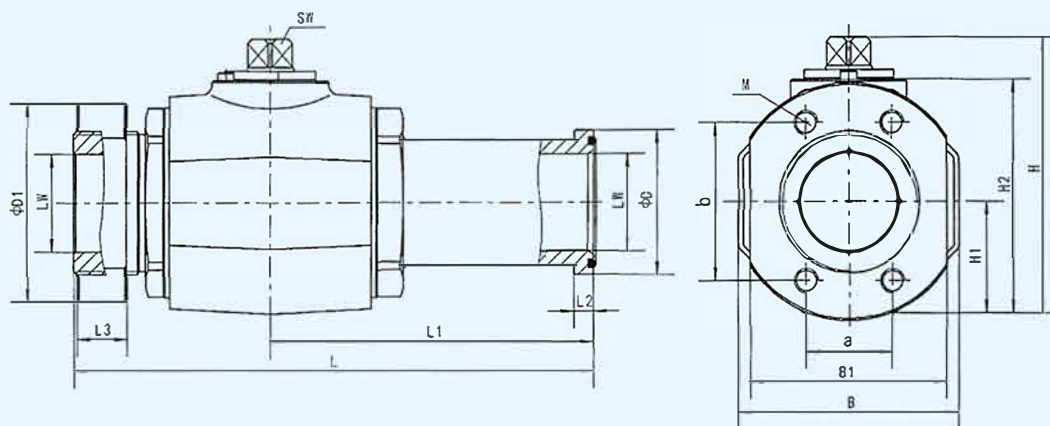

210bar(3000psi)																	
Model	DN	PN	L	L1	L2	L3	D	D1	a	b	M	B	B1	H	H1	H2	SW
MKH-SAE210-32-D/S-Lu-M10	32	210	223.5	137.5	8.1	21	50.8	87	30.2	58.7	M10	82	74	108	41	87.5	17
MKH-SAE210-32-D/S-Lu-M12	32	210	223.5	137.5	8.1	21	50.8	87	30.2	58.7	M12	82	74	108	41	87.5	17
MKH-SAE210-40-D/S-Lu	40	210	248.5	160	8.1	24	60.3	103	35.7	69.8	M12	93	86	119.5	46.5	99	17
MKH-SAE210-50-D/S-Lu	50	210	259.5	161.5	9.6	25	71.4	117	42.9	77.8	M12	110	98	135.5	55	115	17

420bar(6000psi)																	
Model	DN	PN	L	L1	L2	L3	D	D1	a	b	M	B	B1	H	H1	H2	SW
MKH-SAE420-32-D/S-Lu	32	350	322	161	10.4	32	54	103	31.8	66.7	M14	82	78	108	41	87.5	17
MKH-SAE420-40-D/S-Lu	40	350	278.5	190	12.7	32	63.5	120	36.5	79.4	M16	93	96	119.5	46.5	99	17
MKH-SAE420-50-D/S-Lu	50	350	290.5	192.5	12.7	34	79.4	145	44.5	96.8	M20	110	114	135.5	55	115	17

 **Ordering and Usage Notes**

- MKH-SAE210-32-D/S-Lu-M12 is not recommended unless there are special needs. It is recommended to purchase MKH-SAE210-32-D/S-Lu-M10 for the same size, which is more reliable.
- DN13~DN25 supply with 04-Zinc Alloy Bent levers. DN32~DN50 supply with 06-Steel Bent lever. Check annex for more information.



With SAE Split Flange Adapter



Introduction

These two-way high-pressure ball valves are available in the BKH and MKH series with adapters for SAE J518 C-3000 PSI flanges or SAE J518 C-6000 PSI flanges. Flanges are available upon customer request, and they can also be interchanged with JB/ZQ4187-97 split high-pressure flanges.

How to order

BKH - SAE - FS - 210 - 13 - 1 1 2 3 - 04

[1]

[2]

[3]

[4]

[5]

[6]

[7]

[8]

[1] Model: BKH-SAE-FS- Square body

MKH-SAE-FS- Eight-Square body

[2] Pressure setting: 210bar, 420bar

[3] Nominal diameter. 13, 20 .. mm

[4] Body and flange material: 1-Carbon steel (BKH-SAE-FS)

2-Carbon steel (MKH-SAE-FS)

[5] Ball & stem material : 1-Carbon steel; 4-Stainless steel

[6] Ball seat material: 2-POM, 4-PTFE

[7] Connection & stem seal: 3-NBR; 5-FKM

[8] Levers type: 04-Zinc Alloy Bent levers

05-Steel Straight levers

06-Steel Bent levers

Remark: Product selection codes is normal material, it could omit when place order.

BKH-SAE-FS-1123, MKH-SAE-FS-2123

General dimensions

1、BKH-SAE-FS

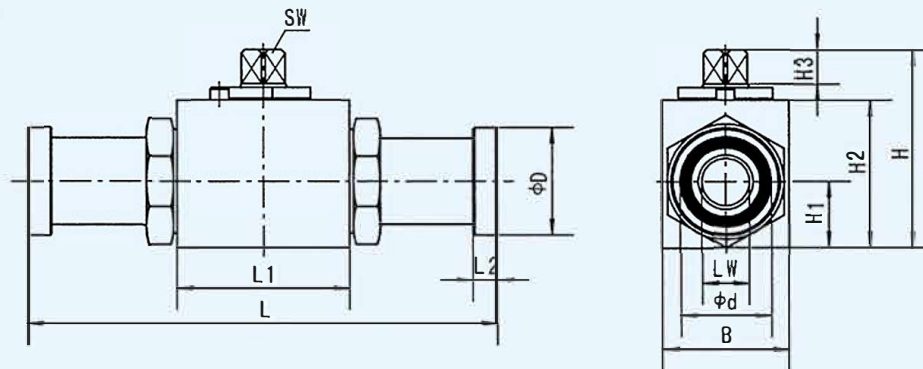

210bar(3000psi)

Model	DN	PN	LW	L	L1	L2	H	H1	H2	H3	B	d	D	SW
BKH-SAE-FS-210	13	350	13	151	48	6.8	52.5	17	40	8	35	25.5	30.2	9
BKH-SAE-FS-210	20	315	19	162	60	6.8	75	24	57	12	48	31.9	38.1	14
BKH-SAE-FS-210	25	315	25	178	65	8.1	82	28.5	64	12	57	39.8	44.4	14

420bar(6000psi)

Model	DN	PN	LW	L	L1	L2	H	H1	H2	H3	B	d	D	SW
BKH-SAE-FS-420	13	420	13	151	48	7.9	52.5	17	40	8	35	25.5	31.8	9
BKH-SAE-FS-420	20	315	19	174	60	8.9	75	24	57	12	48	31.9	41.3	14
BKH-SAE-FS-420	25	315	25	198	65	9.6	82	28.5	64	12	57	39.8	47.6	14

Note: (1) DN=mm;(2)PN=bar

With SAE Split Flange Adapter

2、MKH-SAE-FS

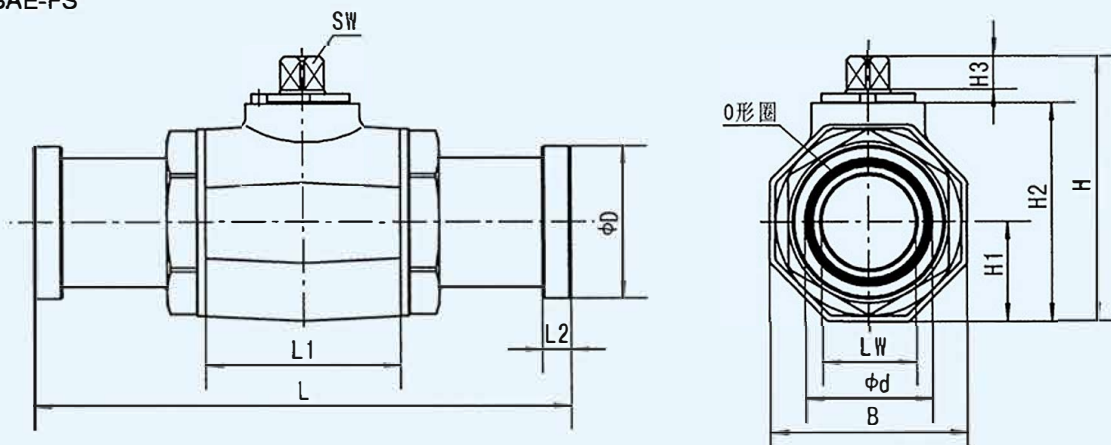

210bar(3000psi)														
Model	DN	PN	LW	L	L1	L2	H	H1	H2	H3	B	d	D	SW
MKH-SAE-FS-210	32	210	30	191	84	8.1	108	41	87.5	14	82	44.5	50.8	17
MKH-SAE-FS-210	40	210	38	231	91	8.1	119.5	46.5	99	14	93	54.1	60.3	17
MKH-SAE-FS-210	50	210	48	232	100	9.6	135.5	55	115	14	110	63.6	71.4	17
MKH-SAE-FS-210	65	175	60	270	110	9.6	154	68.5	133.5	14	Φ137	75.8	84.1	17

420bar(6000psi)														
Model	DN	PN	LW	L	L1	L2	H	H1	H2	H3	B	d	D	SW
MKH-SAE-FS-420	32	350	30	223	84	10.4	108	41	87.5	14	82	44.5	54	17
MKH-SAE-FS-420	40	350	38	281	91	12.7	119.5	46.5	99	14	93	54.1	63.5	17
MKH-SAE-FS-420	50	350	48	316	100	12.7	135.5	55	115	14	110	63.6	79.4	17
MKH-SAE-FS-420	65	315	60	370	110	21.2	158	72.5	137.5	14	Φ145	75.8	108.1	17

Note: The unit of DN is mm, and the unit of PN is bar.

Ordering and Usage Notes

- 1.SAE flanges need to be ordered separately.
- 2.DN13~DN25 supply with 04-Zinc Alloy Bent levers. DN32~DN60 supply with 06-Steel Bent lever. DN65-100 supply with 07 high pressure ball valve lever. Check annex for more information.



With SAE Long Split Flange Connection

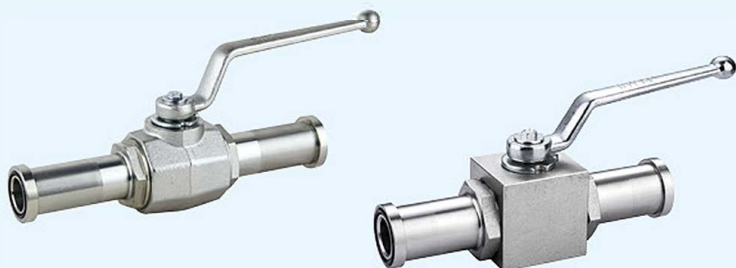

Introduction

These two-way high-pressure ball valves are available in the BKH and MKH series with adapters for SAE J518 C-3000 PSI flanges or SAE J518 C-6000 PSI flanges. Flanges are available upon customer request, and they can also be interchanged with JB/ZQ4187-97 split high-pressure flanges.

How to order

BKH - DN13 - SAEFS210 - Lu - 1 1 2 3 - 04 - Accessory

[1] [2] [3] [4] [5] [6] [7] [8] [9] [10]

[1] Model: BKH Square body

MKH Eight-Square body

[2] Nominal diameter: 13, 20 .. mm

[3] Pressure setting: 210bar, 420bar

[4] Adapter type: LU-SAE long split flange adapter

[5] Body and Flange material: 1-Carbon steel (BKH)
2-Carbon steel (MKH)

[6] Ball & stem material : 1-Carbon steel; 4-Stainless steel

[7] Ball seat material: 2-POM, 4-PTFE, 5-PEEK

[8] Connection & stem seal: 3-NBR; 5-FKM

[9] Levers type: 04-Zinc Alloy Bent levers

05-Steel Straight levers

[10] valve can be offered with locking device or any other accessory like limit switches or actuators. Please check *Ball Valve Annex for more information

General dimensions

BKH-DN※-SAEFS※-Lu

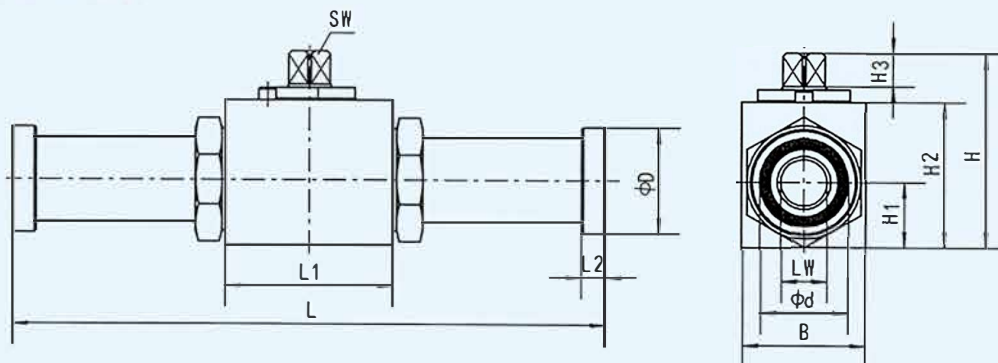

210bar(3000psi)

Model	DN	PN	LW	L	L1	L2	H	H1	H2	H3	B	d	D	SW
BKH-DN13-SAEFS210-Lu	13	350	13	170	48	6.8	52.5	17	40	8	35	25.5	30.2	9
BKH-DN20-SAEFS210-Lu	20	315	19	200	60	6.8	75	24	57	12	48	31.9	38.1	14
BKH-DN25-SAEFS210-Lu	25	315	25	215	65	8.1	82	28.5	64	12	57	39.8	44.4	14

420bar(6000psi)

Model	DN	PN	LW	L	L1	L2	H	H1	H2	H3	B	d	D	SW
BKH-DN13-SAEFS420-Lu	13	420	13	180	48	7.9	52.5	17	40	8	35	25.5	31.8	9
BKH-DN20-SAEFS420-Lu	20	315	19	200	60	8.9	75	24	57	12	48	31.9	41.3	14
BKH-DN25-SAEFS420-Lu	25	315	25	250	65	9.6	82	28.5	64	12	57	39.8	47.6	14



With SAE Long Split Flange Connection

MKH-DN※-SAEFS※-Lu

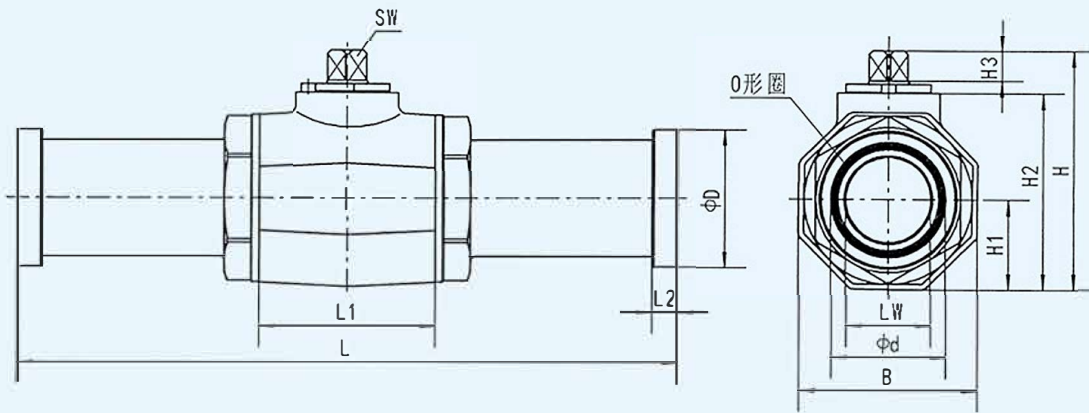

210bar(3000psi)														
Model	DN	PN	LW	L	L1	L2	H	H1	H2	H3	B	d	D	SW
MKH-DN32-SAEFS210-Lu	32	210	30	275	84	8.1	108	41	87.5	14	82	44.5	50.8	17
MKH-DN40-SAEFS210-Lu	40	210	38	320	91	8.1	119.5	46.5	99	14	93	54.1	60.3	17
MKH-DN50-SAEFS210-Lu	50	210	48	323	100	9.6	135.5	55	115	14	110	63.6	71.4	17

420bar(6000psi)														
Model	DN	PN	LW	L	L1	L2	H	H1	H2	H3	B	d	D	SW
MKH-DN32-SAEFS420-Lu	32	350	30	322	84	10.4	108	41	87.5	14	82	44.5	54	17
MKH-DN40-SAEFS420-Lu	40	350	38	380	91	12.7	119.5	46.5	99	14	93	54.1	63.5	17
MKH-DN50-SAEFS420-Lu	50	350	48	385	100	12.7	135.5	55	115	14	110	63.6	79.4	17

Ordering and Usage Notes

- 1.SAE flanges need to be ordered separately.
- 2.DN13~DN25 supply with 04-Zinc Alloy Bent levers. DN32~DN50 supply with 06-Steel Bent lever.



How to order

KH	-	DN65	-	ISO320	-	2	1	2	A
[1]		[2]		[3]		[4]	[5]	[6]	[7]

- [1] Model: KH-Fixed flange ball valve
 [2] Nominal diameter: 50、65、80、100mm
 [3] Connection form and pressure level: ISO 6164 Flange connection
 [4] Body connection material: 2-Carbon steel
 [5] Ball & stem material: 1-Carbon steel
 [6] Ball seat material: 1-POM
 [7] Connection & stem seal: A-NBR 8-FKM

General dimensions

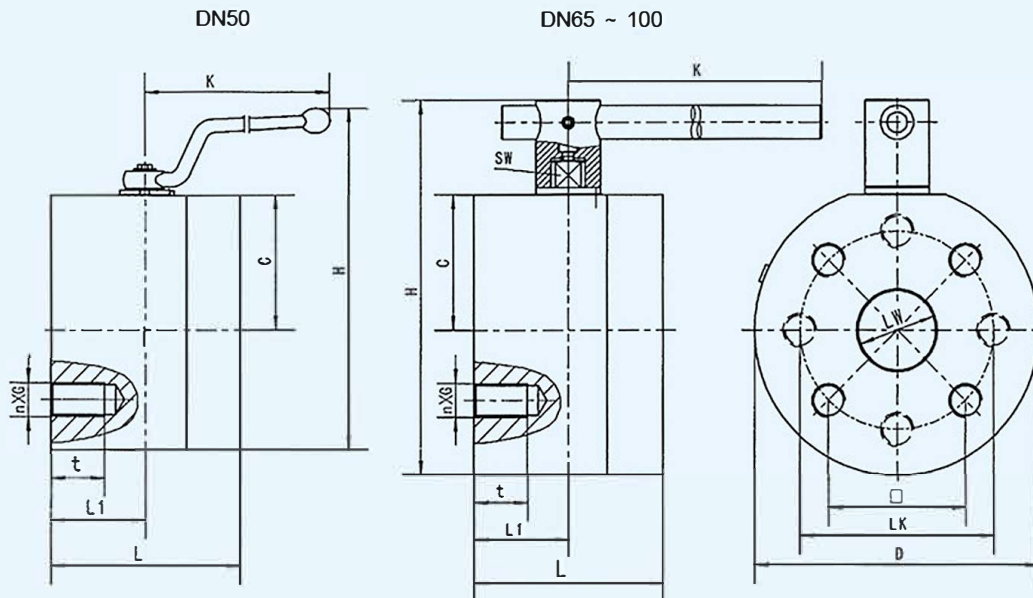

PN400/PN320 Flanged ball valve (flange refer to ISO6164-3 PN400 flange)

型号	PN	LW	L	L1	D	H	C	K	SW	n	G	t	□	LK
KH-DN50-ISO320	400	48	122	61	197	274	94	235	17	4	M20	31	83.4	118
KH-DN65-ISO320	350	60	150	75	224	288	105	500	17	4	M24	36	102.5	145
KH-DN80-ISO320	350	70	170	85	256	333	120	600	20	4	M30	48	123.7	175
KH-DN100-ISO320	320	90	200	100	256	338	121	900	24	8	M24	36	/	200

Ordering and Usage Notes

- DN50 Supply with a 06-Steel Bent levers.
- DN65~DN100 supply with 07 high pressure ball valve lever. Check annex for more information.

How to order



KHBF	-	16	-	PN40	-	1	1	1	2	6
[1]		[2]		[3]		[4]	[5]	[6]	[7]	[8]

- [1] Model: KHBF-Square body DN16-25
KHMf-Eight-Square Body DN32~DN50
(DIN-EN558-1, FTF, basic range 1. long type DIN-3202-F1)
- [2] DN: 16. 20. 25.32.40.50mm
- [3] Pressure setting: 4, 6.3, 16, 25, 31.5MPa
(40,63,160, 250,315bar)
- [4] Body and Connection material: 1-Carbon steel
4-Stainless steel
- [5] Ball & stem material: 1-Carbon steel; 4-Stainless steel
- [6] Ball seat material: 1-POM; 4-PTFE
- [7] Connection & stem seal: 2-NBR; 4-FKM
- [8] Flange material: 6-Carbon steel

Remark): Product selection code 11126 is normal material, it could omit when place order.

General dimensions

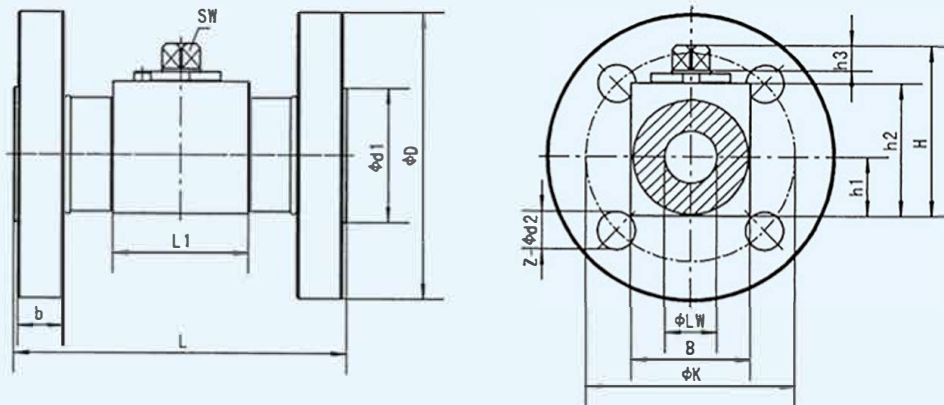

Model	PN	LW	L	L1	D	d1	d2	Z	K	b	B	H	h1	h2	h3	SW
KHBF-16	40	15	130	47	95	45	14	4	65	14	38	63.5	19	46	11	12
	160				105		14	4	75	18						
	315				128		18	4	90	24						
KHBF-20	40	20	150	60	105	55	14	4	75	16	48	75	24	57	12	14
	160															
KHBF-25	40	25	160	65	115	65	14	4	100	22	57	82	28.5	64	12	14
	160				138		18	4	105	26						
	250				148		22	4	115	32						
	315				158		22	4								

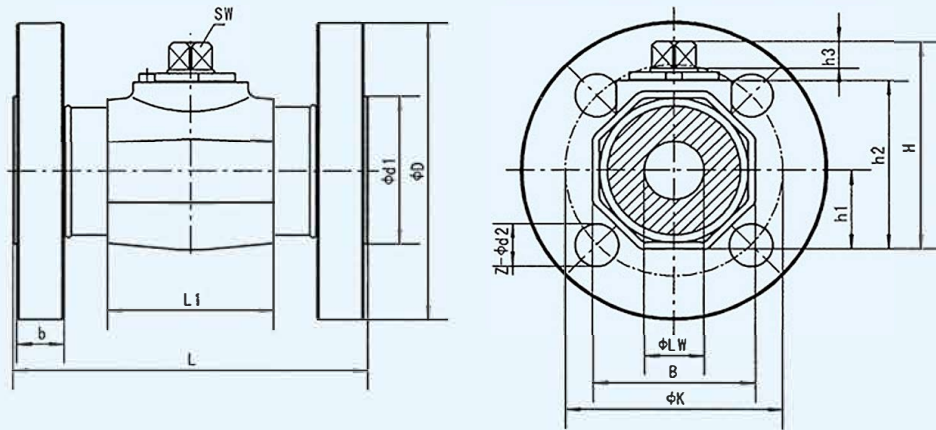

Model	PN	LW	L	L1	D	d1	d2	Z	K	b	B	H	h1	h2	h3	SW
KHMF-32	40	30	180	84	138	78	18	4	100	16	82	108	41	87.5	14	17
	160				155		22	4	110	24						
KHMF-40	40	38	200	91	148	88	18	4	110	16	93	119.5	46.5	99	14	17
	160				168		22	4	125	26						
	250				185		26	4	135	32						
	315				195		26	4	145	36						
KHMF-50	40	48	230	100	165	102	18	4	125	18	110	135.5	55	115	14	17
	63				178		22	4	135	24						
	160				195		26	4	145	28						
	250				198		26	8	150	36						
	315				208		26	8	160	40						

PN bar

Ordering and Usage Notes

1. The Product selection codes 4, 5, 6, and 7, which corresponds to the 1,1,1, and 2 configuration, is the default standard combination.

No additional labeling is required unless there are specific requirements.

2. Z is the amount of mounting holes for flange

3. Supply with a 06-Steel Bent levers

60° Internal Taper Seal Hydraulic Ball Valve



How to order

KHB	-	NZ60	-	M20	-	1	1	1	2	-	04
[1]		[2]		[3]		[4]	[5]	[6]	[7]		[8]

- [1] Model: KHB- 2-way ball valve
- [2] 60° inner cone seal
- [3] Threaded connection type
- [4] Body and connection material: 1-Carbon steel
4-Stainless steel
- [5] Ball & stem material: 1-Carbon steel; 4-Stainless steel
- [6] Ball seat material: 1-POM; 4-PTFE; 5-PEEK
- [7] Connection & stem seal: 2-NBR; 4-FKM
- [8] Levers type: 04-Zinc Alloy Bent levers
06-Steel Bent levers

General dimensions

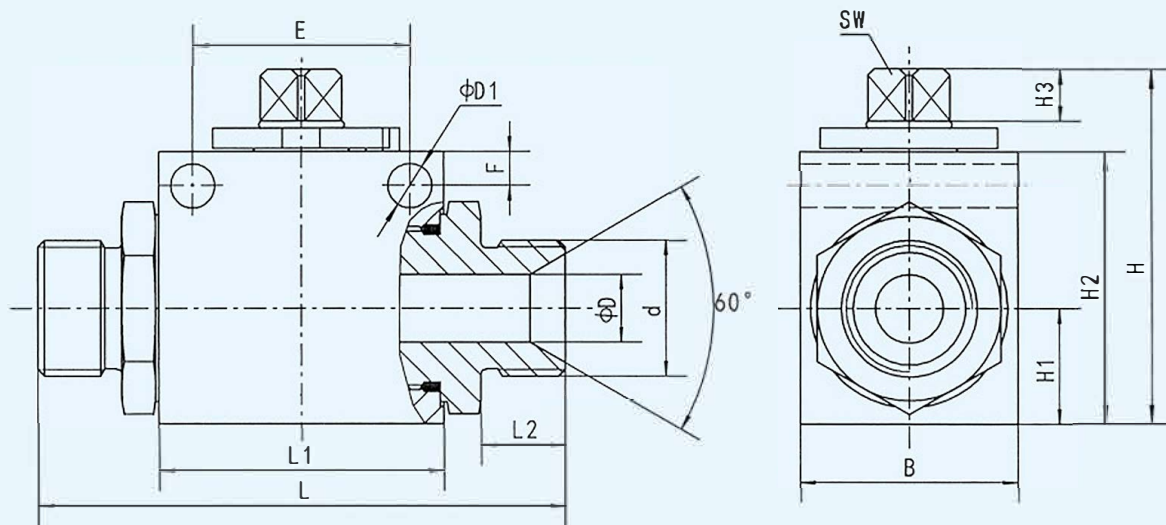

JB984-77 MALE METRIC THREAD

Model	DN	PN	D	d	D1	E	F	B	L	L1	L2	H	H1	H2	H3	SW
KHB-NZ60-M16	8	500	8	M16×1.5	6.5	32	5	32	78	42	12.5	52.5	17	40	8	9
KHB-NZ60-M20	10	500	10	M20×1.5	6.5	32	5	32	81	42	14	52.5	17	40	8	9
KHB-NZ60-M27	13	500	13	M27×1.5	6.5	37.5	4.8	35	90	48	15	52.5	17	40	8	9

JB984-77 Pipe thread

Model	DN	PN	D	d	D1	E	F	B	L	L1	L2	H	H1	H2	H3	SW
KHB-NZ60-G1/4	6	500	6	G1/4	4.5	26	5	28	73	37	12	44.5	13	32	8	9
KHB-NZ60-G3/8	8	500	8	G3/8	6.5	32	5	32	79	42	13.5	52.5	17	40	8	9
KHB-NZ60-G1/2	10	500	10	G1/2	6.5	32	5	32	86	42	16	52.5	17	40	8	9
KHB-NZ60-G3/4	16	400	15	G3/4	6.5	37.5	5	38	98	47	18.5	63.5	19	46	11	12
KHB-NZ60-G1	20	315	20	G1	6.5	45	6.5	48	116	60	20.5	75	24	57	12	14

PN=bar

60° Internal Taper Seal Hydraulic Ball Valve

How to order



KHB3K	-	NZ60	-	M20	L	-	1	1	1	2	-	04
[1]		[2]		[3]	[4]		[5]	[6]	[7]	[8]		[9]

- [1] KHB3K-NZ Series 60° Internal Taper Seal Hydraulic Ball Valve
- [2] 60° inner cone seal
- [3] Threaded connection type
- [4] Functional symbol of 3-way ball valve: L, T
- [5] Body and connection material: 1-Carbon steel
4-Stainless steel
- [6] Ball & stem material: 1-Carbon steel; 4-Stainless steel
- [7] Ball seat material: 1-POM; 4-PTFE; 5-PEEK
- [8] Connection & stem seal: 2-NBR; 4-FKM
- [9] Levers type: 04-Zinc Alloy Bent levers
06-Steel Bent levers

Porting patterns (See chart)

ATTENTION: Hydraulic oil can flow into the valve through port 1!

The valve can only be sealed under two specific situations:

- (1) Pressure at the closed port is zero;
- (2) Pressure at the closed port is lower than at the two open ports.

Porting pattern

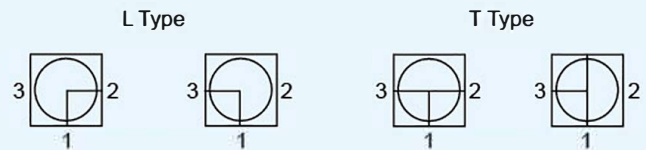

General dimensions

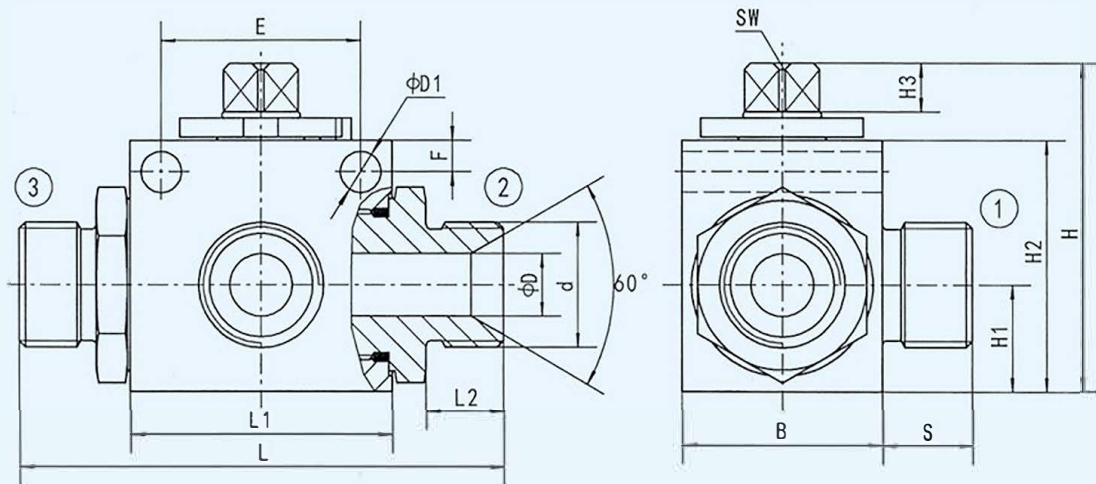

JB984-77 MALE METRIC THREAD

Model	DN	PN	D	d	D1	E	F	B	L	L1	L2	H	H1	H2	H3	S	SW
KHB3K-NZ60-M16	8	315	8	M16×1.5	6.5	32	5	32	78	42	12.5	52.5	17	40	8	12.5	9
KHB3K-NZ60-M20	10	315	10	M20×1.5	6.5	32	5	32	81	42	14	52.5	17	40	8	14.5	9
KHB3K-NZ60-M27	13	315	13	M27×1.5	6.5	37.5	4.8	35	90	48	15	52.5	17	40	8	15	9

Note: The unit of DN is mm, and the unit of PN is bar.



How to order

GB3V	-	G1/2	-	L	-	1	1	1	2	-	04
[1]		[2]		[3]		[4]	[5]	[6]	[7]		[8]

- [1] Model: GB3V-3-way Ball Valve
- [2] Threaded connection type for adapter:
- [3] Porting pattern: See chart of porting pattern
- [4] Body and Connection material: 1-Carbon steel
4-Stainless steel
- [5] Ball & stem material: 1-Carbon steel; 4-Stainless steel
- [6] Ball seat material: 1-POM; 4-PTFE; 5-PEEK
- [7] Connection & stem seal: 2-NBR; 4-FKM
- [8] Levers type: 04-Zinc Alloy Bent levers
06-Steel Bent levers

Porting patterns (See chart)

ATTENTION: Hydraulic oil can flow into the valve through port 1!
The valve can only be sealed under two specific situations:
(1) Pressure at the closed port is zero:
(2) Pressure at the closed port is lower than at the two open ports.
(3) Please order Model GB3VS in case you need pressure inlet from all ports.

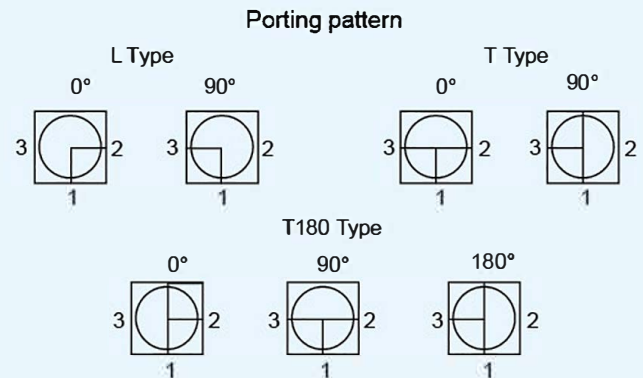

General dimensions

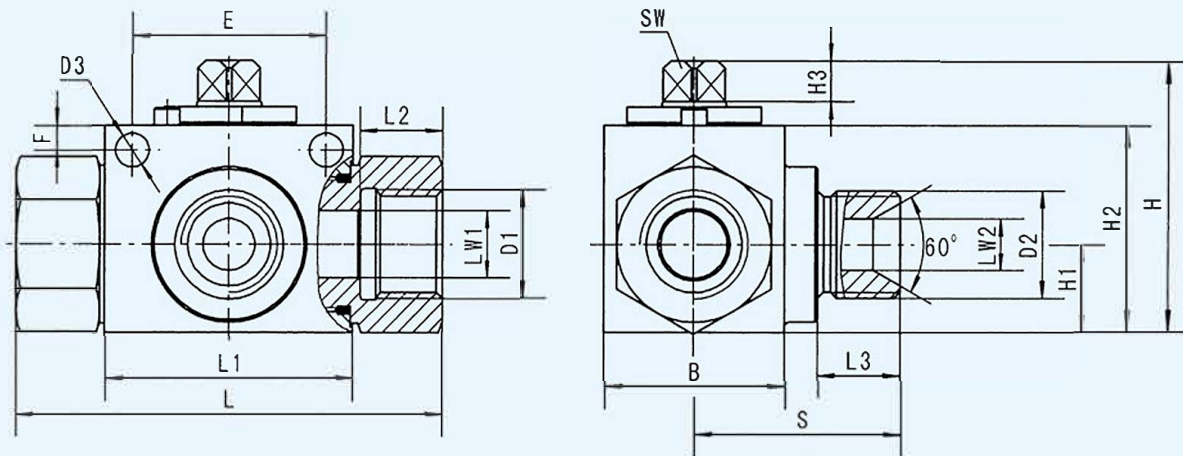

ISO 228 for both Female thread, the center oil port is 60° male thread inner cone or port combination gasket seal.

Model	DN	PN	LW1	LW2	L	L1	L2	L3	D1	D2	D3	B	H	H1	H2	H3	S	E	F	SW
GB3V -G1/4	6	315	6	6	69	37	14	12	G1/4	G1/4A	4.5	28	44.5	13	32	8	35	26	5	9
GB3V -G3/8	10	315	10	8	72	42	14	13.5	G3/8	G3/8A	6.5	32	52.5	17	40	8	36	32	5	9
GB3V -G1/2	13	315	13	10	83	48	16	16	G1/2	G1/2A	6.5	35	52.5	17	40	8	40	37.5	4.8	9
GB3V -G3/4	20	315	20	16	95	60	18	18.5	G3/4	G3/4A	6.5	48	72	24	57	12	49	45	6.5	14
GB3V -G1	25	315	25	21	113	65	20.5	20.5	G1	G1A	6.7	57	82	28.5	64	12	56.5	55	6	14

Unit for PN is bar



How to order

BBKH	-	10	-	1123	-	1	-	FF
[1]		[2]		[3]		[4]		[5]

- [1] Model: BBKH
- [2] Nominal diameter: 10, 13, 20, 25mm
- [3] Material: 1123-Carbon steel,
NBR (connection seal),
POM (ball seat)
- [4] Surface finishing: 1-Zinc plating (yellow); 2-Cr3 plating (silver)
- [5] Connection type: FF-Double female connector
FM-One female connector, one male connector

General dimensions

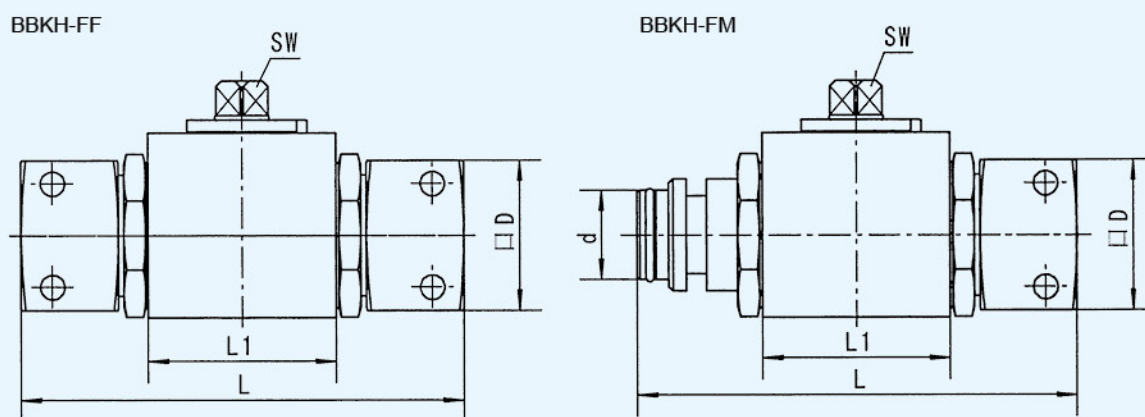

Model	DN	PN(bar)	L	L1	D	d	SW
BBKH-10-1123-FF	10	500	113	42	30	-	9
BBKH-10-1123-FM						14	
BBKH-13-1123-FF	13	500	118	48	35	-	9
BBKH-13-1123-FM						18	
BBKH-20-1123-FF	20	315	138	60	40	-	14
BBKH-20-1123-FM						24	
BBKH-25-1123-FF	25	315	151	65	52	-	14
BBKH-25-1123-FM						31	

Connections complied with SAE J1467 and DIN 20043.



How to order

KHB	-	12LR	-	NSL	-	1	1	1	2	-	04
[1]		[2]		[3]		[4]	[5]	[6]	[7]		[8]

- [1] Model: KHB
- [2] Threaded connection type for adapter
- [3] Combination method: NSL
- [4] Body and connection material: 1-Carbon steel
- [5] Ball & stem material: 1-Carbon steel; 4-Stainless steel
- [6] Ball seat material: 1-POM; 4-PTFE; 5-PEEK
- [7] Connection & stem seal: 2-NBR; 4-FKM
- [8] Levers type: 04-Zinc Alloy Bent levers
05-Steel Straight levers
06-Steel Bent levers

General dimensions

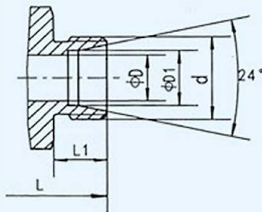
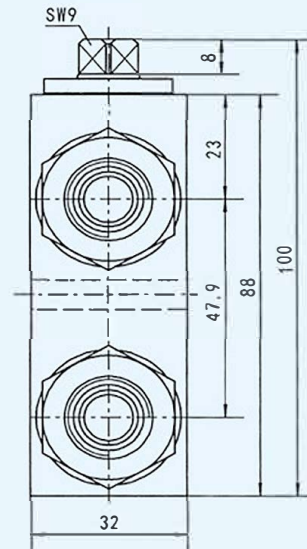
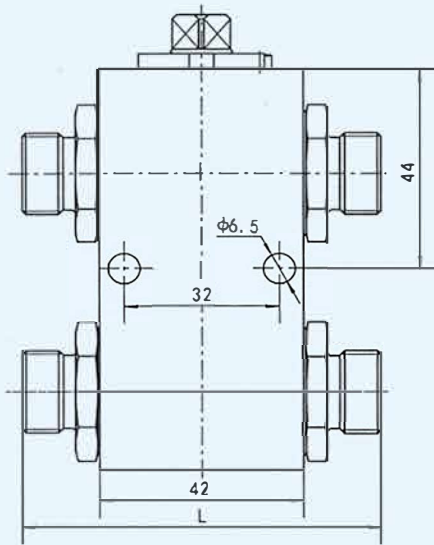

DIN 2353 / ISO 8434-1 Light series

Model	DN	PN	D	D1	d	L	L1
KHB-12LR-NSL	10	350	10	12	M18×1.5	74	11

PN=bar

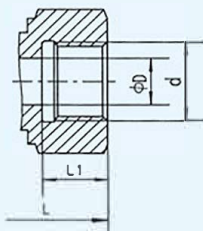

DIN ISO 228 Female thread

Model	DN	PN	D	d	L	L1
KHB-G3/8-NSL	10	350	10	G3/8	72	14

PN=bar



Flow Control Check Ball Valve



Introduction

This valve integrates various functions, including switching, flow control, check valve, ball valve. For details, please refer to the Circuit Diagram. The port stand by JIS B2351 Standard.

General dimensions

Circuit Diagram

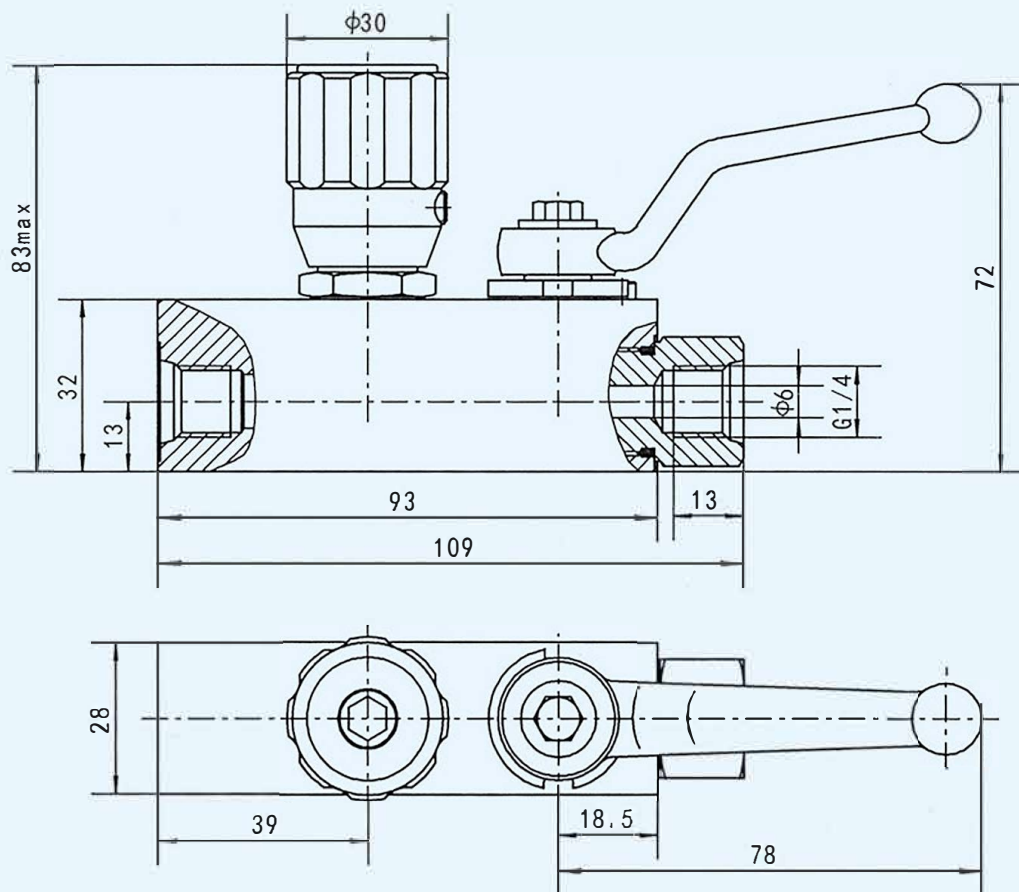
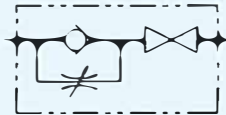

Right-angle Articulated Hydraulic Ball Valve



How to order

KHB	-	12LR	-	M18	-	1	1	1	2	-	04
[1]		[2]		[3]		[4]	[5]	[6]	[7]		[8]

- [1] Product series code
- [2] Threaded connection type for adapter:
- [3] Threaded connection type for plug
- [4] Body, Adapter and blot material: 1-Carbon steel
4-Stainless steel
- [5] Ball & stem material: 1-Carbon steel; 4-Stainless steel
- [6] Ball seat material: 1-POM; 4-PTFE; 5-PEEK
- [7] Connection, stem seal and Plug sealing material: 2-NBR; 4-FKM
- [8] Levers type: 04-Zinc Alloy Bent levers

General dimensions

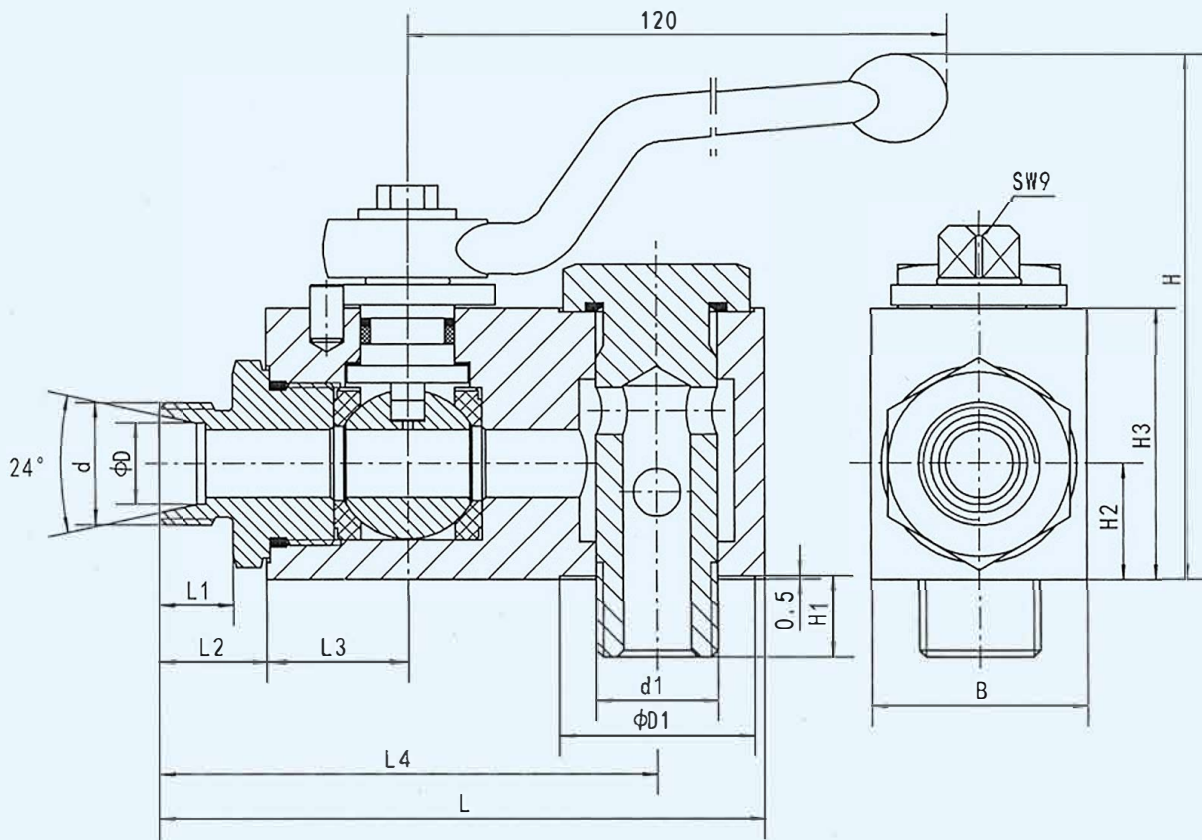

Model	DN	PN	D	d	D1	d1	L	L1	L2	L3	L4	B	H	H1	H2	H3
KHB-10LR-M16	8	500	10	M16×1.5	29	M16×1.5	90	11	16	21	74	32	80	12	17	40
KHB-12LR-M18	10	500	12	M18×1.5	29	M18×1.5	90	11	16	21	74	32	80	12	17	40
KHB-12SR-M20	8	500	12	M20×1.5	29	M20×1.5	97	12	17	21	80	32	80	14	17	40
KHB-14SR-M20	10	500	14	M22×1.5	29	M20×1.5	99	14	19	21	82	32	80	14	17	40

Note: The unit of DN is mm, and the unit of PN is bar.

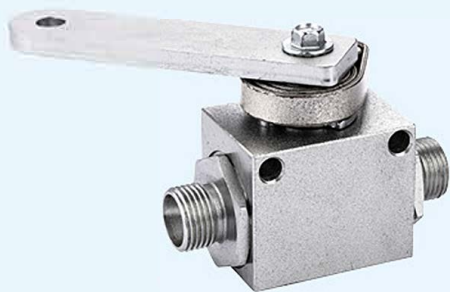

Circuit diagram

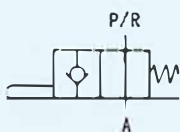

How to order

HKHB	-	12LR	-	1	1	1	2
[1]		[2]		[3]	[4]	[5]	[6]

- [1] Model: HKHB
- [2] Threaded connection type for adapter
- [3] Body and connection material: 1-Carbon steel
- [4] Ball & stem material: 1-Carbon steel;
4-Stainless steel
- [5] Ball seat material: 1-POM; 5-PEEK
- [6] Connection & stem seal: 2-NBR; 4-FKM

General dimensions

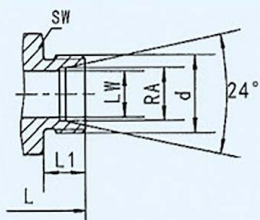
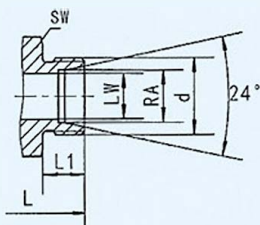
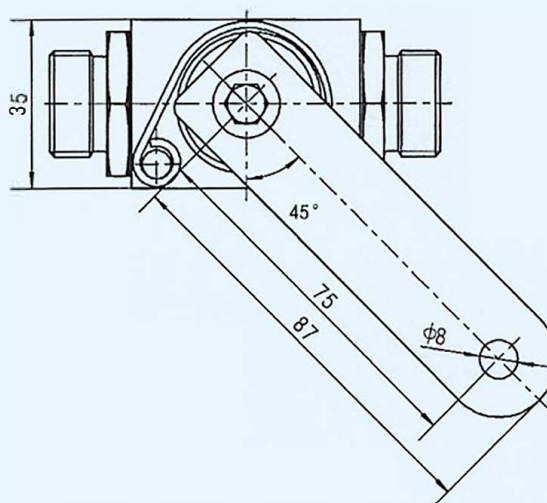
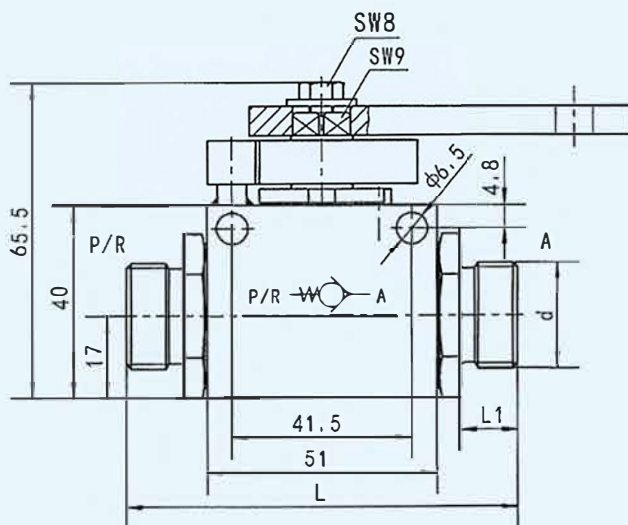

DIN 2353 / ISO 8434-1 Light series

Please check pressure rating of the pipe fittings

Model	DN	PN _{bar}	LW	RA	d	L	L1	SW
HKHB-12LR	10	400	10	12	M18×1.5	81	11	30
HKHB-15LR	13	400	13	15	M22×1.5	83	12	30

DIN 2353 / ISO 8434-1 Heavy series

Model	DN	PN _{bar}	LW	RA	d	L	L1	SW
HKHB-14SR	10	400	10	14	M18×1.5	87	14	30
HKHB-16SR	13	400	13	16	M22×1.5	87	14	30

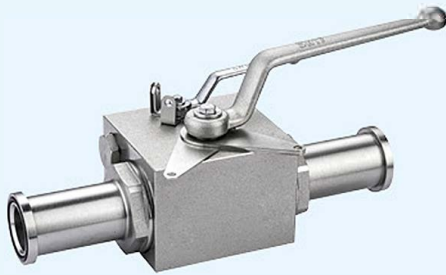

Introduction

Bypass ball valve is a type of valve that features a smaller ball valve installed within a bypass system, which is connected to a larger ball valve. This configuration allows the ball valve to function pipeline pressure balance and provides a variety of flow rate options

How to order

PTH	-	DN32	-	SAEFS210
[1]		[2]		[3]

- [1] Model: PTH Bypass ball valve
- [2] Nominal diameter: DN32 DN40 DN50
- [3] Connection & pressure ratings

Circuit diagram

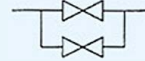

General dimensions

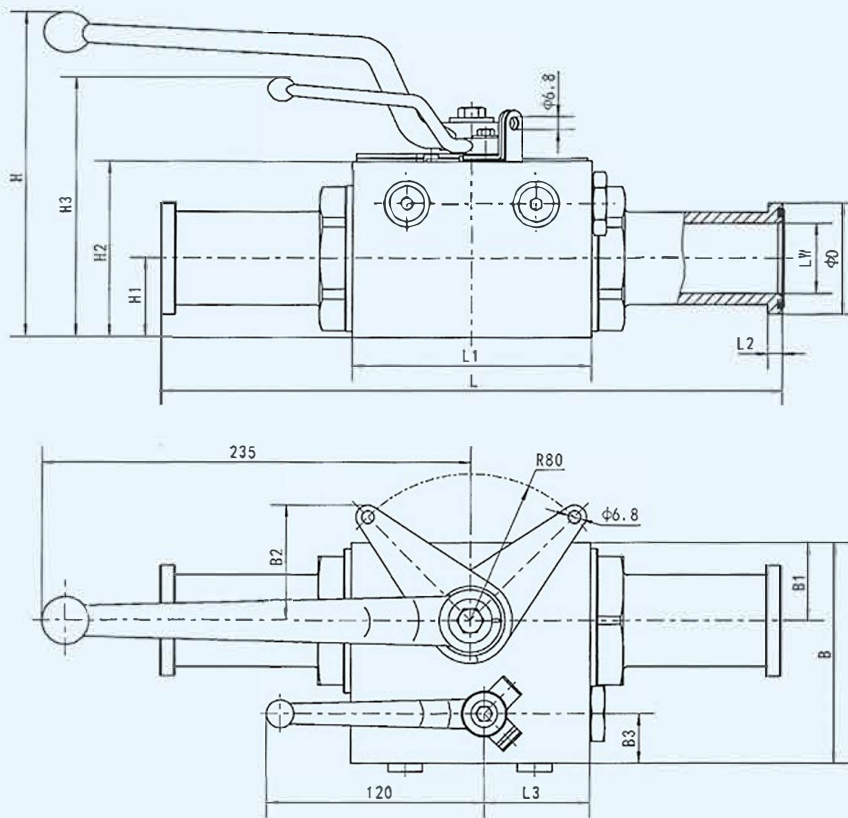

Model	DN	PN	LW	D	L	L1	L2	B	B1	B2	B3	H	H1	H2	H3
PTH-DN32-SAEFS210	32	210	30	50.8	320	118	8.1	98	37.5	63	21	165.5	37.5	84	129.5
PTH-DN40-SAEFS210	40	210	38	60.3	340	131	8.1	120	42.5	63	27	176.5	42.5	95	140.5
PTH-DN50-SAEFS210	50	210	48	71.4	360	142	9.6	145	52.5	63	27	194	52.5	112.5	158

DIN 2353 Heavy series

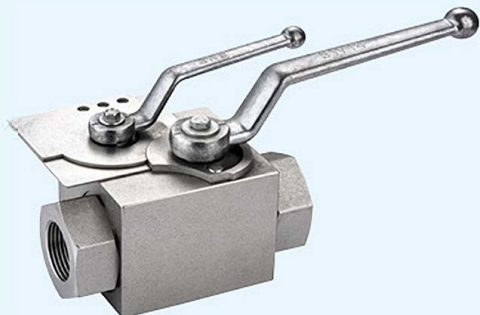

How to order

XHF	-	DN25	-	G1	-	G1/4	1	1	1	2	-	04
[1]		[2]		[3]		[4]	[5]	[6]	[7]	[8]		[9]

- [1] Model: XHF
- [2] Main valve nominal diameter: DN13、DN20、DN25
- [3] Main valve port connection thread
- [4] Pressure relief port connection thread: G1/4
- [5] Body & connection material: 1-carbon steel
4-stainless steel
- [6] Body & stem material: 1-carbon steel
4-stainless steel
- [7] Ball seat material: 1-POM、5-PEEK
- [8] Connection & stem seal: 2-NBR、4-FKM
- [9] Levers type: 04-zinc alloy bend levers
06-steel bend levers

1112 is normal material combination, it could be omitted in ordering.

General dimensions

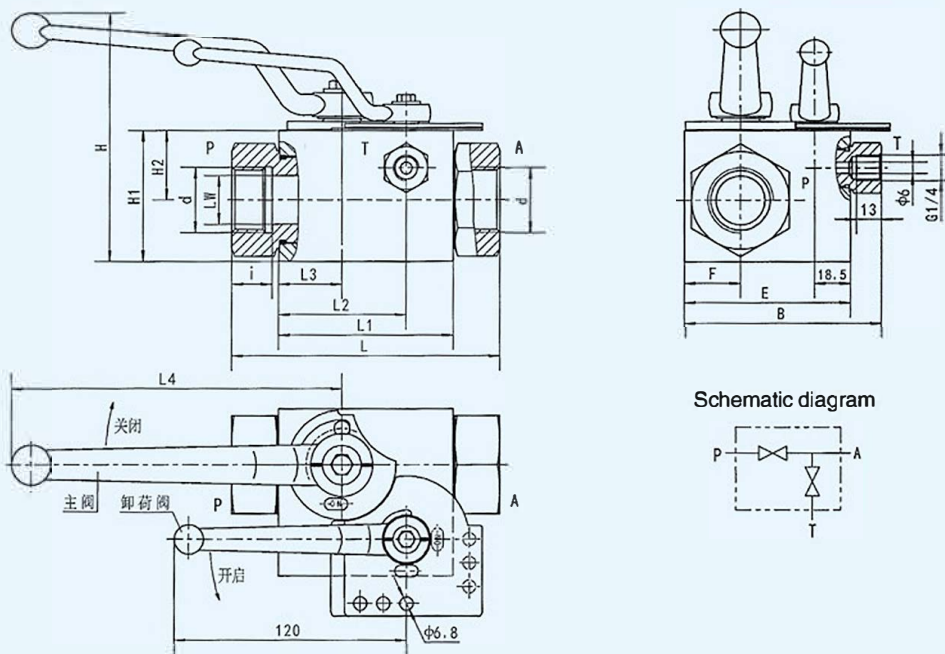

Model	LW	d	i	L	L1	L2	L3	L4	B	E	F	H	H1	H2
XHF-DN13-G1/2-G1/4	13	G1/2	16	103	68	51	24	120	84	68	22	91	45	23
XHF-DN20-G3/4-G1/4	20	G3/4	18	120	85	63.5	30	170	101	85	28.5	120	60	33
XHF-DN25-G1-G1/4	25	G1	20.5	138	90	66	32.5	170	101	85	28.5	127	67	35.5



KHB 2-way ball valve

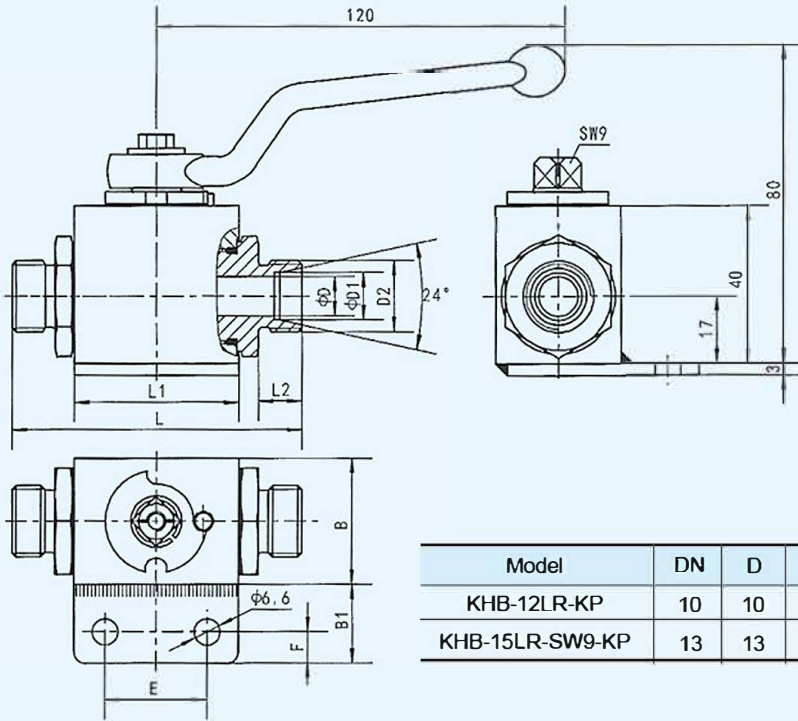

KHB 2-way ball valve

Model	DN	D	D1	D2	L	L1	L2	B	B1	E
KHB-12LR-KP	10	10	12	M18×1.5	74	42	11	32	20	26
KHB-15LR-SW9-KP	13	13	15	M22×1.5	82	48	12	35	35	30

KHB3K 3-way ball valve

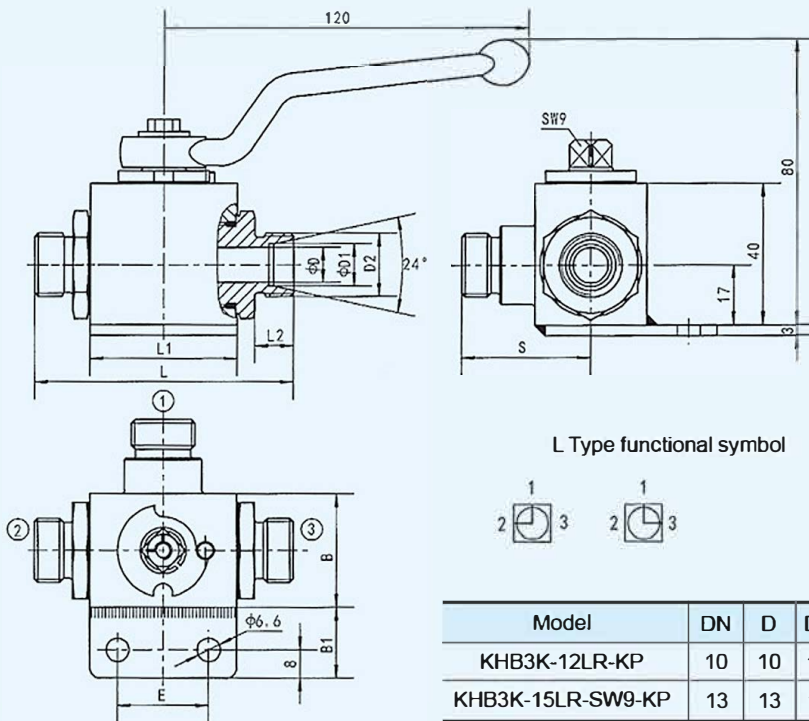

KHB3K 3-way ball valve

Model	DN	D	D1	D2	L	L1	L2	B	B1	E	S
KHB3K-12LR-KP	10	10	12	M18×1.5	74	42	11	32	20	26	37
KHB3K-15LR-SW9-KP	13	13	15	M22×1.5	82	48	12	35	35	30	40

Ordering and Usage Notes

1. The KP series involves welding mounting plate flanges onto standard KHB and KHB3K ball valves.
2. To place an order for a ball valve with a welding mounting plate, simply add "-KP" to the standard valve.
3. If you have specific requirements for the ball valve mounting plate dimensions, please contact us.



KHB-G1/4-DKP

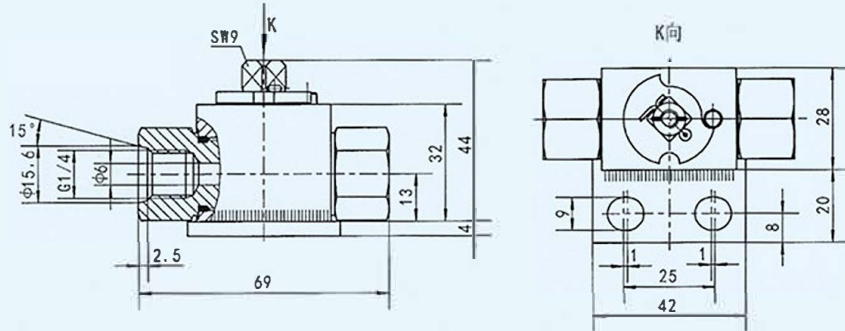

KHB-G1/2-CKP Side welding plate ball valve

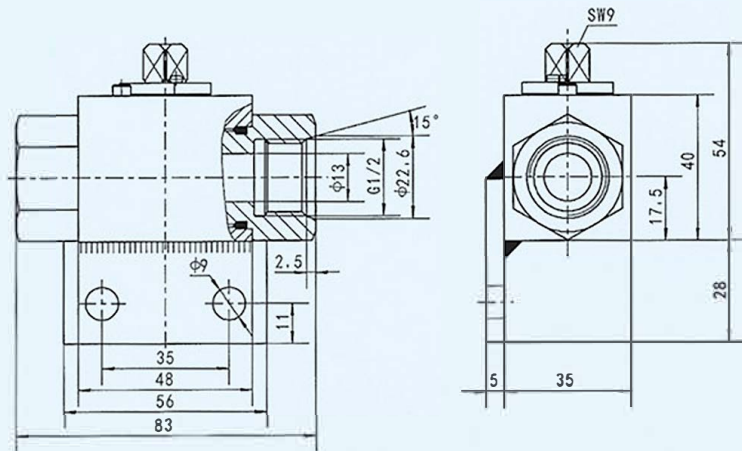

KHB3K-G1/2-L-DKP Bottom welding plate three way ball valve

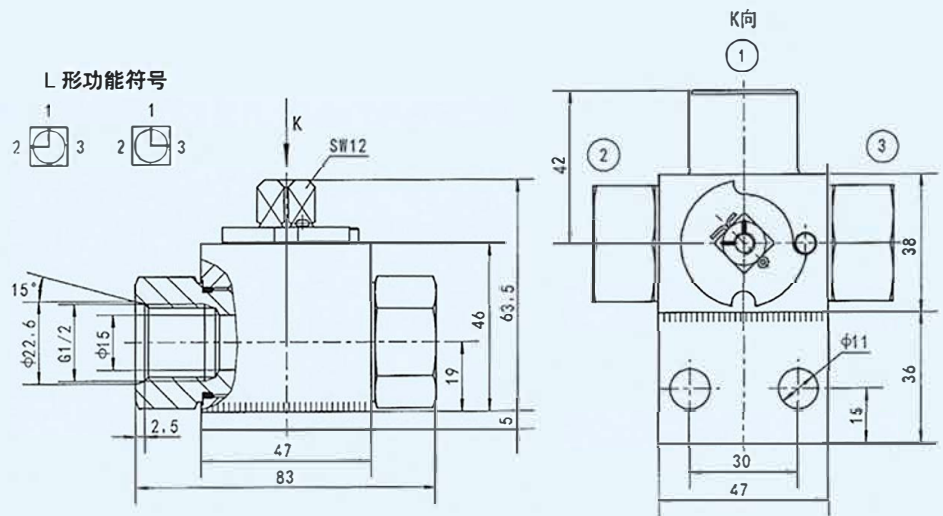



How to order

KHNV	N	-	G1/2	-	2233
[1]	[2]		[3]		[4]

- [1] Model: KHNV Low pressure ball valve
- [2] N- Standard type
- [3] Connection type
- [4] Material: Body, connector and stem Brass with nickel plating
 Ball- Stainless steel
 Ball seat -PTFE
 Connection seal by NBR or PTFE

General dimensions

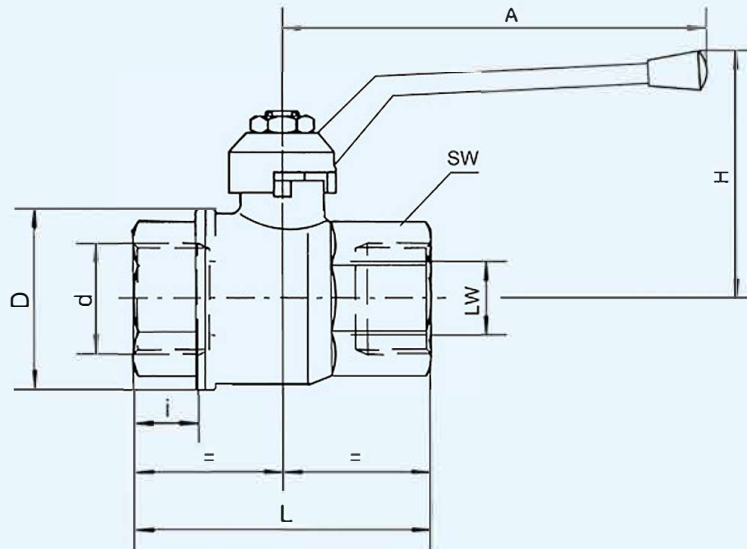

Model	DN	PN _{bar}	LW	d	D	i	L	A	H	SW
KHNVN-G1/4	6	64	10	G1/4	26	11.5	51.5	95	48	21
KHNVN-G3/8	10	64	10	G3/8	26	11.5	51.5	95	48	21
KHNVN-G1/2	15	40	14	G1/2	33	13.5	55	95	51	25
KHNVN-G3/4	20	40	19	G3/4	39	12.5	57	110	60	31
KHNVN-G1	25	30	24	G1	49	15	69.5	110	64	38
KHNVN-G1¼	32	30	30	G1¼	59	17	81.5	160	79	48
KHNVN-G1½	40	30	38	G1½	73	18	95	160	85	54
KHNVN-G2	50	30	48	G2	86	22	113	170	103	67

04-Zinc Alloy Bent levers

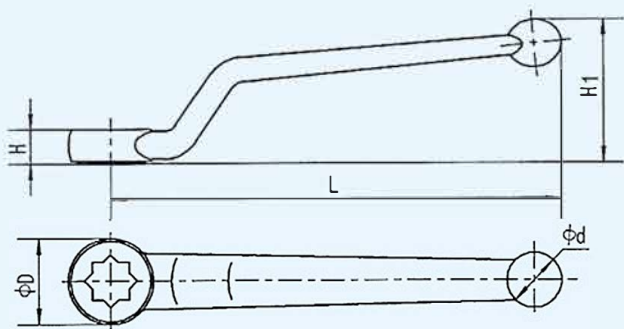

SW	L	H	H1	D	d	Hexbolt
9*	78	8.5	33	22,5	13	M5X10
9	120	8.5	41	25	15	M5X10
12	155	12	50	28.5	19	M6X10
14	170	13	55	32	20.5	M6X10

05-Steel Straight levers

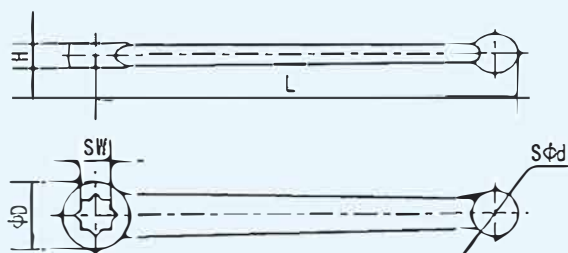

SW	L	H	D	d	Hexbolt
9	145	8.5	24	16	M5X10
12	180	12	28	20	M6X10
14	200	13	32	21	M6X10
17	260	15	36	24	M8X12

06-Steel Bent levers

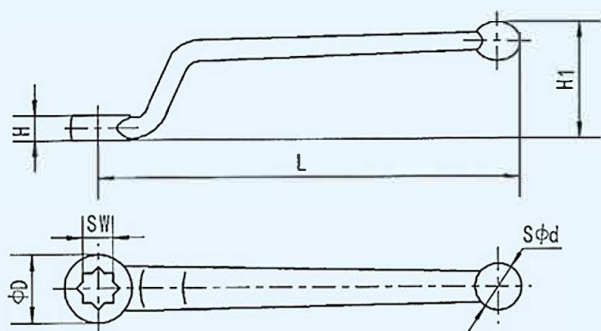

SW	L	H	H1	D	d	Hexbolt	Remark
9	130	8.5	38	26	16	M5X10	
12	165	12	50	31	20	M6X10	
12	165	12	55	31	20	M6X10	For round flange
14	181	13	61	33	21	M6X10	
14	181	13	67	33	21	M6X10	For round flange
17	235	15	75	36	24	M8X12	

07 high pressure ball valve lever

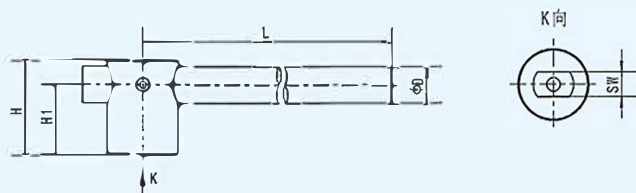

SW	L	H	H1	D	socket head screw	For ball valve
17	500	66	48	28	M8X20	DN65 ※
20	600	78	58	30	M10X20	DN80
24	900	82	61	32	M10X20	DN100
36	900	93	72	32	M12X25	DN125

Ball Valve Mounting Holes Series

Side mounting hole

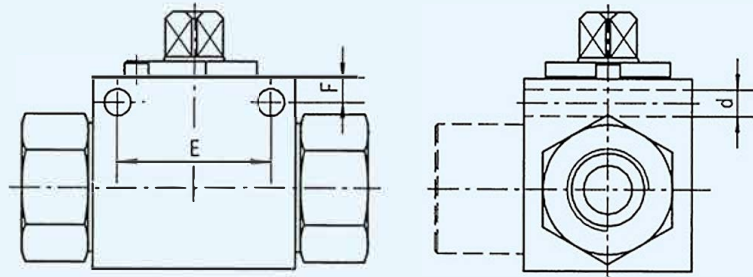

DN	E	F	d
4	26	5	4.5
6	26	5	4.5
10	32	5	6.5
13	37.5	4.8	6.5
16	37.5	5	6.5
20	45	6.5	6.5
25	55	6	6.7
25/32	55	6	6.7

Single side thread mounting hole

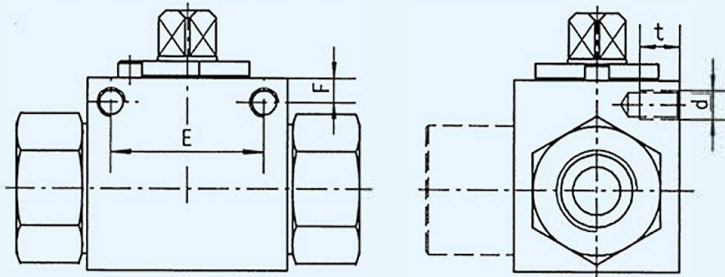

DN	E	F	t	d
4	24	6	6.5	M6
6	24	6	6.5	M6
10	32	5.5	7	M6
13	36	6	8.5	M6
16	32	8	7	M6
20	45	7.5	12	M10
25	45	7.5	12	M10
25/32	45	7.5	12	M10

2 sides thread mounting hole

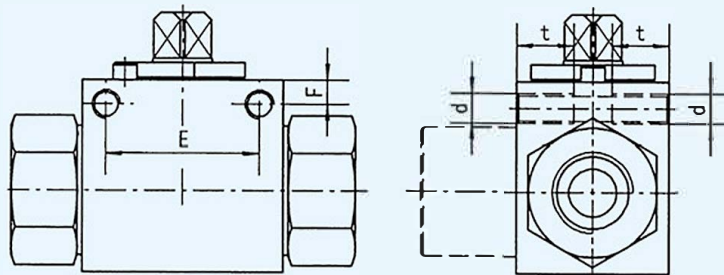

DN	E	F	t	d
4	24	4.5	9	M6
6	24	4.5	9	M6
10	32	5.5	12	M6
13	36	5	12	M6
16	32	6.5	12	M6
20	45	7.5	12	M6
25	45	7.5	12	M6
25/32	45	7.5	12	M6



Board type install thread hole

DN4-DN6

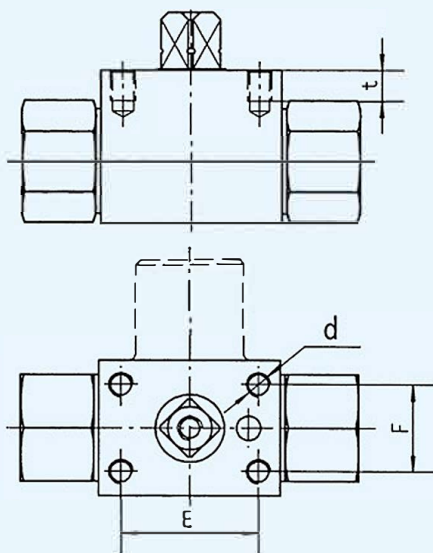

DN	E	F	t	d
4	28	18	6.5	M5
6	28	18	6.5	M5

DN10-25/32

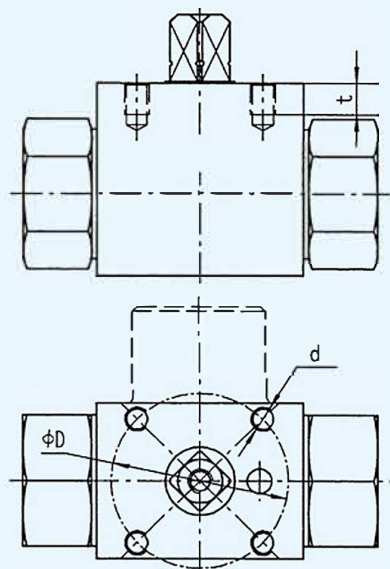

DN	D	d	t	ISO 5211
10	36	M5	7	F03
13	36	M5	7	F03
16	42	M5	8	F04
20	50	M6	10	F05
25	50	M6	10	F05
25/32	50	M6	10	F05

Pls contact us if you have any special requirements of mounting hole.

KHB, KHM Series Ball Valves With Pneumatic Actuator

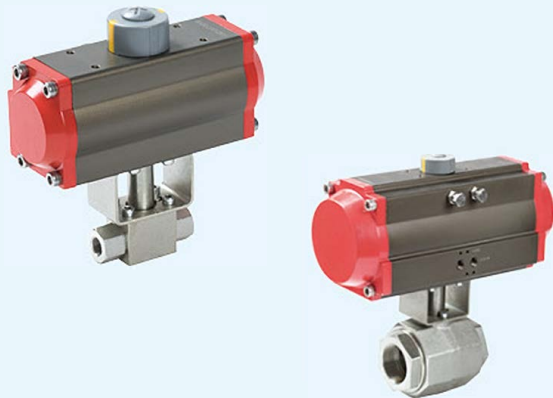

 **How to order**

KHB - G3/8 - 1112 - D H
 [1] [2] [3]

- [1] Ball valve model: KHB Series ball valve
KHM Series ball valve
- [2] D: Double acting pneumatic actuator
- [3] H: High pressure ball valve

 **General dimensions**

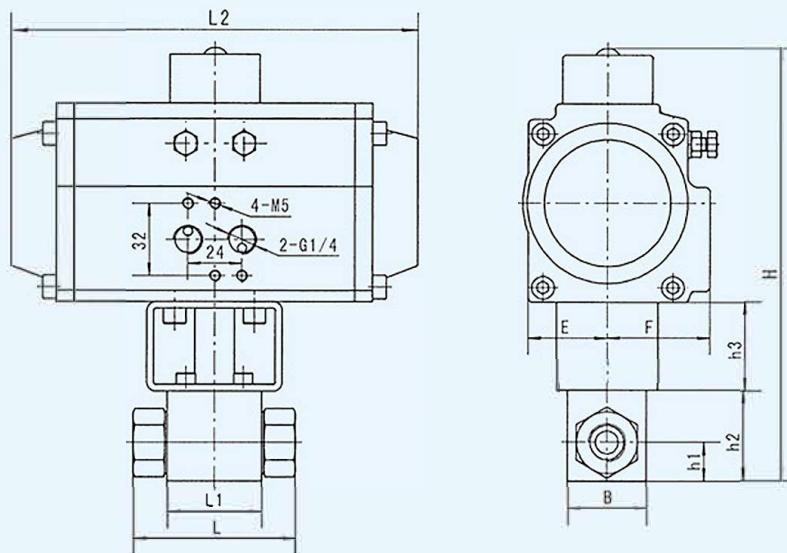

Model	DN	PN	L	L1	L2	B	H	h1	h2	h3	E	F	Actuator Model
KHB-G1/8-DH	4	500	69	37	164	28	169.5	13	32	40	25	42	AT052-DA
KHB-G1/4-DH	6	500	69	37	164	28	169.5	13	32	40	25	42	AT052-DA
KHB-G3/8-DH	10	500	72	42	181	32	195	17	40	40	35.5	45.5	AT063-DA
KHB-G1/2-SW9-DH	13	500	83	48	181	35	195	17	40	40	35.5	45.5	AT063-DA
KHB-G1/2-SW12-DH	16	400	83	47	207	38	222	19	46	50	38.5	52.5	AT075-DA
KHB-G3/4-DH	20	315	95	60	212	48	251.5	24	57	60	46	56.5	AT083-DA
KHB-G1-DH	25	315	113	65	212	57	258.5	28.5	64	60	46	56.5	AT083-DA
KHB-G1'4-DH	25/32	315	120	65	212	60	258.5	28.5	64	60	46	56.5	AT083-DA
KHB-G1'2-DH	25/40	315	130	65	212	60	258.5	28.5	64	60	46	56.5	AT083-DA
KHM-G1'4-DH	32	315	110	84	287	82	305.5	41	87.5	60	52	64	AT0105-DA
KHM-G1'2-DH	40	315	130	91	287	93	317	46.5	99	60	52	64	AT0105-DA
KHM-G2-DH	50	315	140	100	312.5	110	355	55	115	60	60	73.5	AT0125-DA

PN bar

**How to order****KHB - G3/4 - 1112 - DW**

[1]

[2]

[1] Ball valve type

[2] With positioning plunger buttons: DW

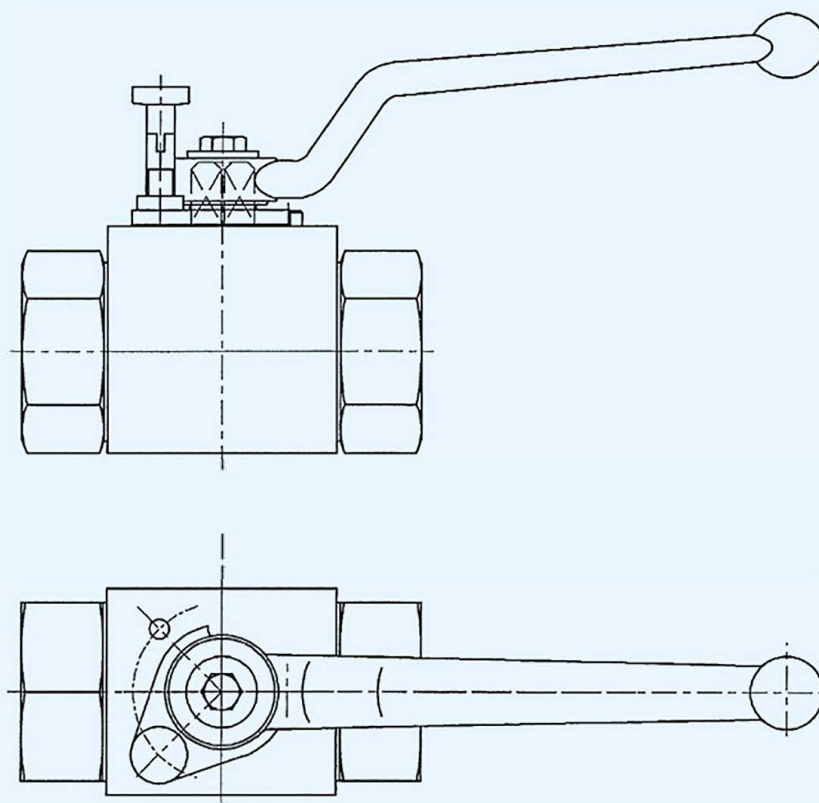
General dimensions**Ordering and Usage Notes**

1. The working principle involves securing the ball valve in a fixed working position using a spring pin to prevent the ball valve from rotating and accidental operation.
2. In theory, any square valve block can be installed with a spring pin.
3. If you need this accessory, simply add -DW to the Product selection codes when placing an order.



Ball Valves Locking Devices DS Series



How to order

KHB - G1/2 - 1112 - DS 9

[1] [2] [3]

[1] Model: KHB KHM Series

[2] Locking Device Series code: DS

[3] Locking device size: 9 14 17

Note: Specifications are not required when ordering with ball valves.
Order separately with specifications, such as DS9 DS14 DS17

General dimensions

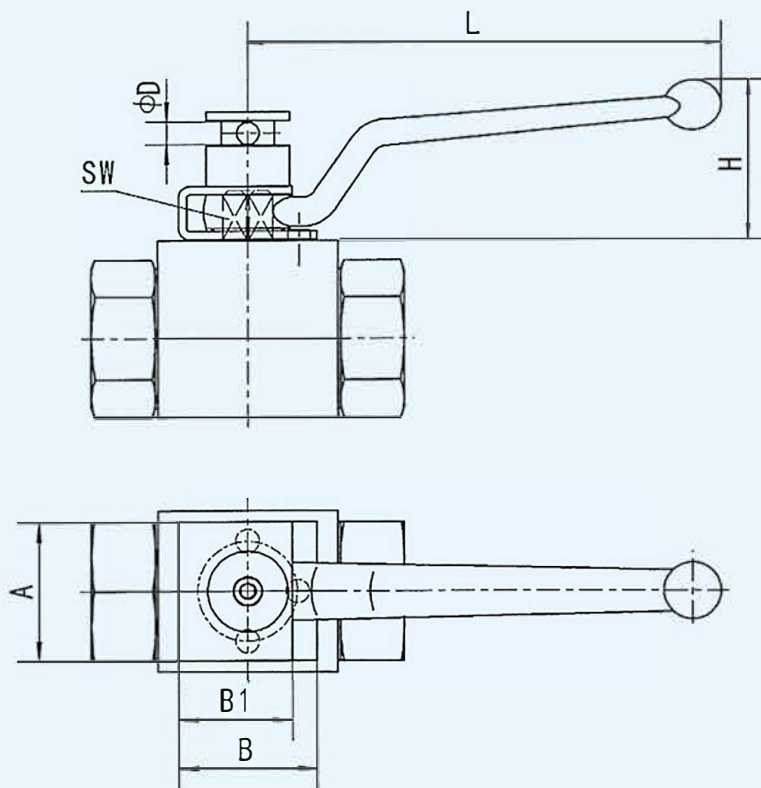

Model	DN (adapt to ball valvediameter)	SW (ball valve stem)	A	B	B1	D	H	L
DS9	4-13	9	32	34	28	6	45	120
DS14	20-25	14	50	50	41	8	60	170
DS17	32-50	17	58	55	46	8	80	235



Ball Valves Locking Devices DST Series



How to order

KHB	-	G1/2	-	1112	-	DST	9
		[1]				[2]	[3]

[1] Model: KHB KHM Series

[2] Locking Device Series code: DST

[3] Locking device size: 9 12 14 17

Note: Specifications are not required when ordering with ball valves.

Order separately with specifications, such as DS9 DS12 DS14 DS17

General dimensions

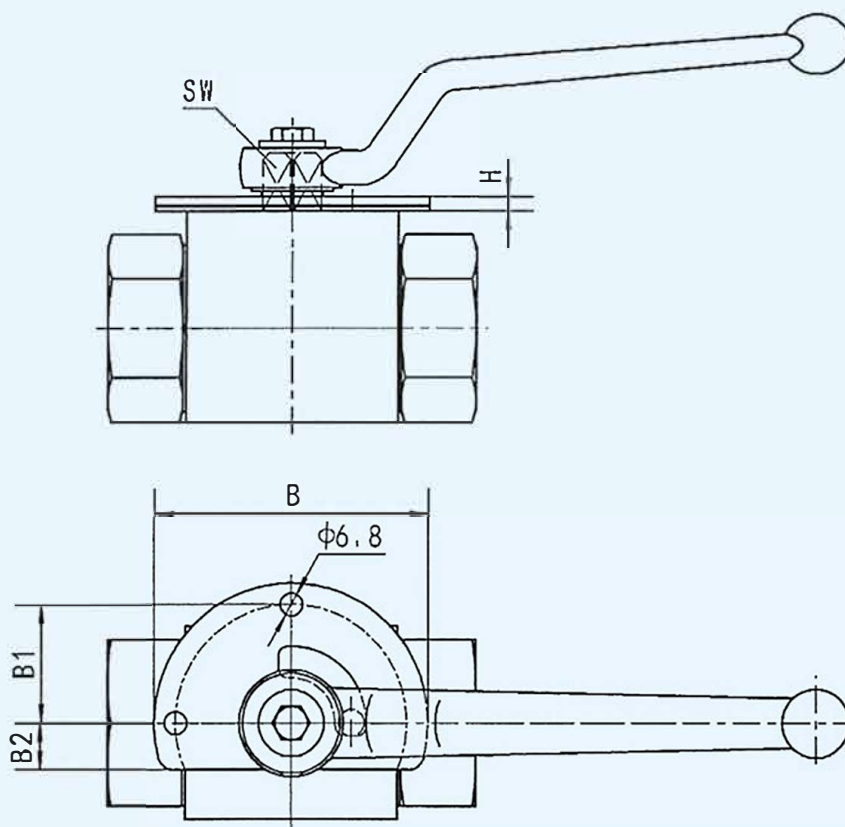

Model	DN (Adapt to ball valve diameter)	SW (Ball valve stem)	B	B1	B2	H
DST9	4-13	9	61	24	10	3.5
DST12	16	12	64	25,5	12	4.5
DST14	20-25	14	84	35.5	14	4,5
DST17	32-50	17	136	61.5	18	4.5



Ball Valves Locking Devices **DXT** Series



How to order

KHB3K - G3/8 - L 1112 - DXT 9

[1] [2] [3]

[1] Model: KHB3K Series

[2] Locking Device Series code: DXT

[3] Locking device size: 9 12 14 17

Note: Specifications are not required when ordering with ball valves.

Order separately with specifications, such as DXT9 DXT12
DXT14 DXT17

General dimensions

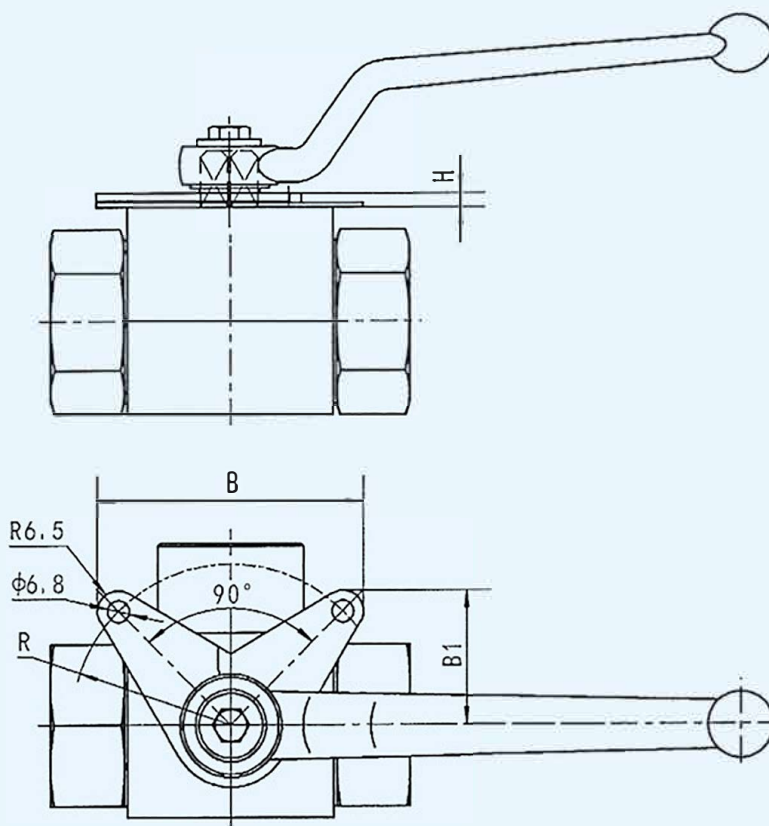

Model	DN (Adapt to ball valve diameter)	SW (Ball valve stem)	B	B1	R	H
DXT9	4-13	9	59	29.5	32.5	3.5
DXT12	16	12	69,5	35	40	4.5
DXT14	20-25	14	84	42	50	4.5
DXT17	32-50	17	126	63	80	4.5



Ball Valves Locking Devices DSP Series



How to order

KHP - 10 - 1112 - DSP 9
 [1] [2] [3]

[1] Model: KHP KHZ KH3K Series

[2] Locking Device Series code: DSP

[3] Locking device size: 9 12 14 17

Note: Specifications are not required when ordering with ball valves.

Order separately with specifications, such as DSP9 DSP12 DSP14 DSP17; KHP-06

General dimensions

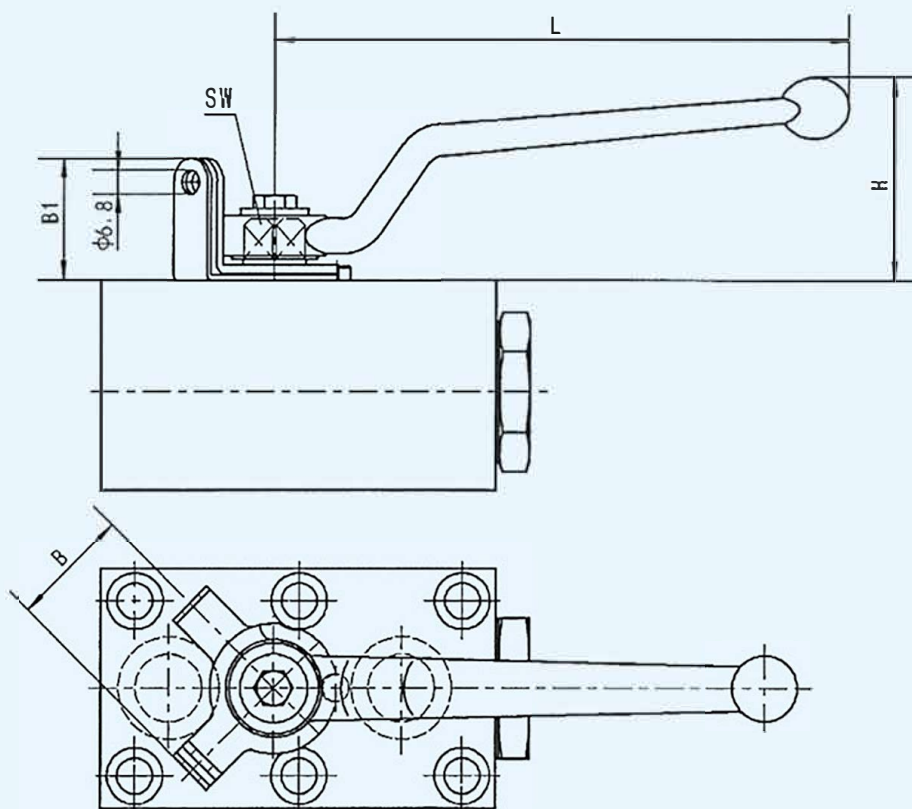

Model	DN (Adapt to ball valve diameter)	SW (Ball valve stem)	B	B1	R	H
DSP9	10-13	9	22	28	120	45
DSP12	16	12	32	34	155	55
DSP14	20-25	14	35	36	170	60
DSP17	32-50	17	37	38	235	81



Set With Mechanical Limit Switch



Introduction

The limit switch can convert the opening or closing status of the ball valve into an electrical signal, facilitating remote display and monitoring of the opening and closing status of the ball valve.

How to order

KHB-G3/8-1112-04 - E 3 0

[1] [2] [3] [4]

- [1] Ball valve type (XH ball valve)
- [2] E — Limit switch control
- [3] 0 — Not assemble limit switch
 - 1 — Monitoring ball valve opening position
 - 2 — Monitoring ball valve closing position
 - 3 — Monitoring ball valve opening & closing position
- [4] 0 — Limit switch is touch type (thread ball valve)
 - 00 — Limited switch is rocker type (manifold ball valve)
 - 000 — Limited switch is closed to induction switch (thread ball valve)

General dimensions

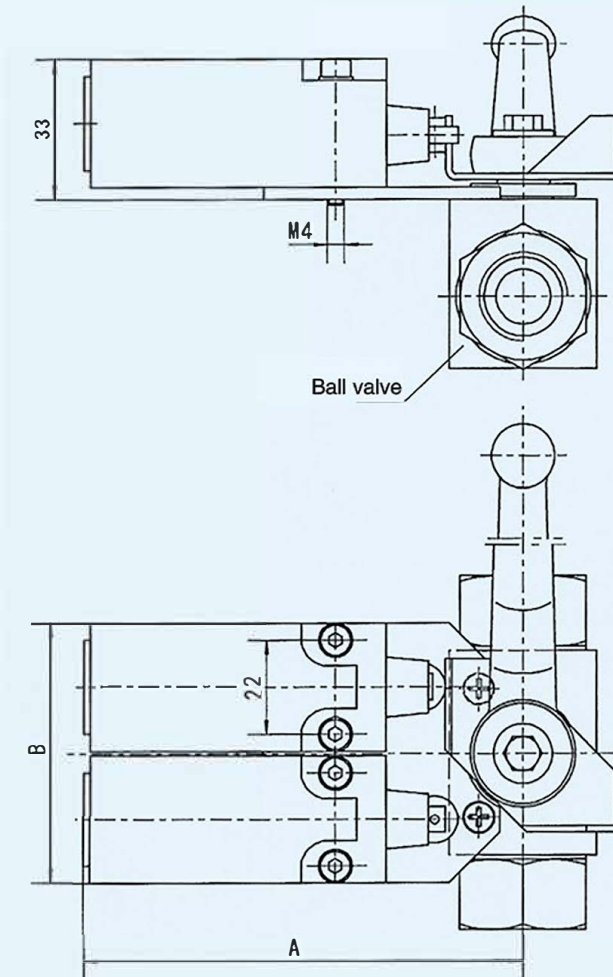

Touch type limited switch
 Model: XCKN2102P20C
 Protection ratings: IP65
 Ambient air temp.: -25~70°C

Limit switch wiring diagram

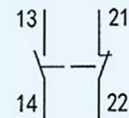

Ball valve nominal diameter	A	B
DN4~13	104	61
DN16	108	68
DN20~25	108	68
DN32~50	115	72



Set With Mechanical Limit Switch & Locking Device

Introduction

The limit switch can convert the opening or closing status of the ball valve into an electrical signal, facilitating remote display and monitoring of the opening and closing status of the ball valve.

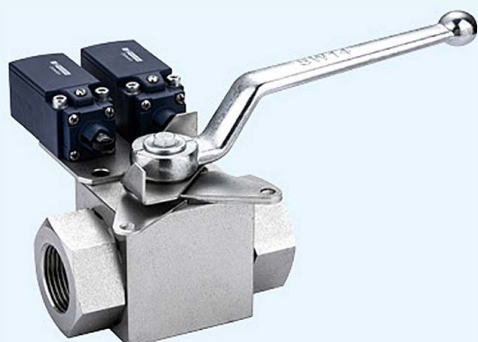

How to order

KHB-G3/8-1112-04 - E 3 0 - DXT
 [1] [2] [3] [4] [5]

- [1] Ball valve type (XH ball valve)
- [2] E — Limit switch control
- [3] 0 — Not assemble limit switch
 - 1 — Monitoring ball valve opening position
 - 2 — Monitoring ball valve closing position
 - 3 — Monitoring ball valve opening & closing position
- [4] 0 — Limit switch is touch type (thread ball valve)
- [5] DXT-Locking device

General dimensions

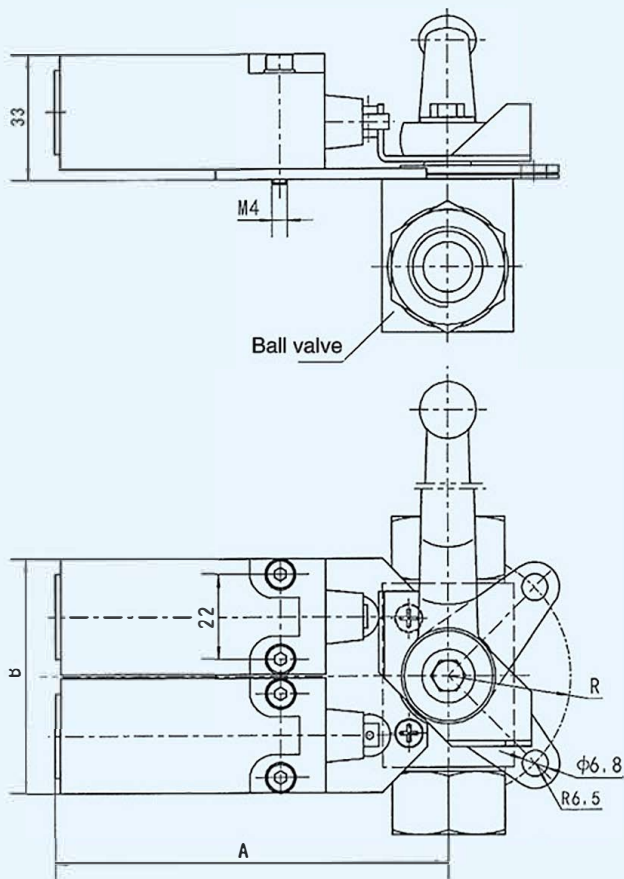

Touch type limit switch
 Model: XCKN2102P20C
 Protection ratings: IP65
 Ambient air temp.: -25~70°C

Limit switch wiring diagram

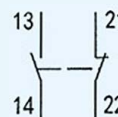

Ball valve nominal diameter	A	B	R
DN4~13	104	61	32.5
DN16	108	68	40
DN20~25	108	68	50
DN32~50	115	72	80



Introduction

Pipeline-installed check valves are suitable for hydraulic systems with low viscosity fluids. Their standard material is typically galvanized carbon steel. Therefore, they are particularly suitable for non-corrosive mineral hydraulic oils and liquids.

How to order

HSP	-	1000	-	2	-	5
[1]		[2]		[3]		

- [1] Model: HSP-Pipeline-installed check valves
- [2] Model for size and thread
- [3] Opening pressure: 5 - 5psi
65 - 65psi

General dimensions

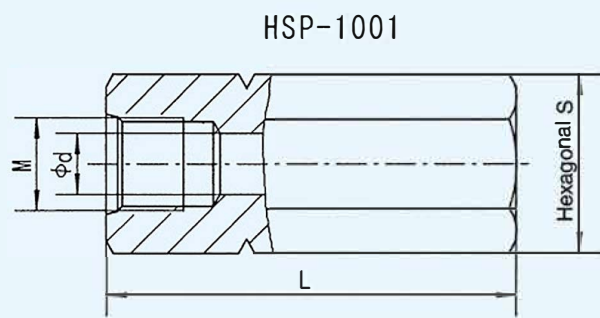
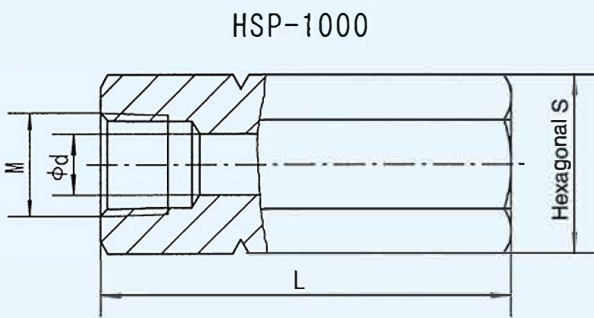

Model	M	d	L	S
HSP-1000-2	1/4NPT	6.5	62	22
HSP-1000-3	3/8NPT	9	73	24
HSP-1000-4	1/2NPT	12.5	95	32
HSP-1000-6	3/4NPT	15	110	36
HSP-1000-8	1NPT	18	120	46
HSP-1000-10	1 1/4NPT	26	140	60
HSP-1000-12	1 1/2NPT	28	140	65

Model	M	d	L	S
HSP-1001-4	7/16-20UNF	6	62	22
HSP-1001-6	9/16-18UNF	8	73	24
HSP-1001-8	3/4-16UNF	12.5	95	32
HSP-1001-12	1 1/16-12UN	15	110	36
HSP-1001-16	1 5/16-12UN	18	120	45
HSP-1001-20	1 5/8-12UN	26	140	60
HSP-1001-24	1 7/8-12UN	28	140	65

Ordering and Usage Notes

Tubular one-way valve with connecting thread of 3/8NPT and opening pressure of 5psi, model: HSP-1000-3-5;
 Tubular one-way valve with connecting thread of 3/4-16UNF and opening pressure of 65psi, model: HSP-1001-8-65;



Introduction

Pipeline-installed check valves are suitable for hydraulic systems with low viscosity fluids. Their standard material is typically galvanized carbon steel. Therefore, they are particularly suitable for non-corrosive mineral hydraulic oils and liquids.

How to order

ATR - G1/2 - 0.5
 [1] [2] [3]

[1] Model: ART-Pipeline-installed check valves

[2] Model for size and thread

[3] Opening pressure: 0.5 - 0.5bar

5 - 5bar

General dimensions

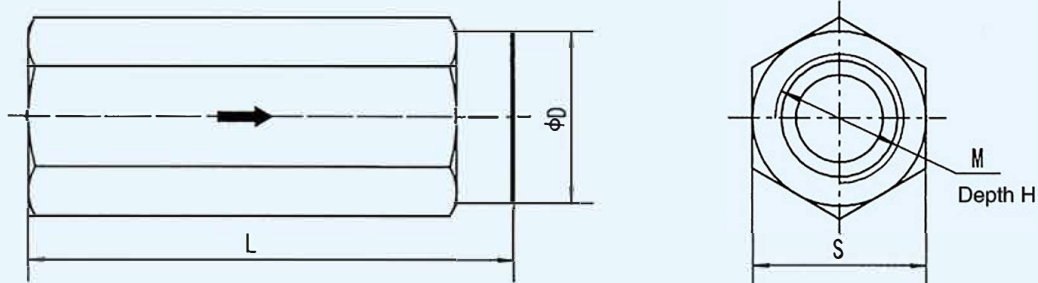

Model	DN	PN(bar)	L	D	S	M	H
ATR-G1/4	6	400	62	18.5	19	G1/4	12
ATR-G3/8	10	400	70	23.5	24	G3/8	14
ATR-G1/2	12	350	77	29.5	30	G1/2	16
ATR-G3/4	16	350	90	35.5	36	G3/4	18
ATR-G1	20	350	106	45.5	46	G1	20
ATR-G1 ¹ / ₄	25	250	130	54.5	55	G1 ¹ / ₄	22
ATR-G1 ¹ / ₂	30	250	140	64.5	65	G1 ¹ / ₂	24
ATR-G2	40	250	160	74.5	75	G2	26



How to order

LA	-	G	10	-	G3/8	-	V
[1]		[2]	[3]		[4]		[5]

- [1] Model: L-flow control valve
LA-flow control check valve
- [2] Connection type: Non-manifold mounting piping type
G- connection by female thread
- [3] Diameter: 6. 8. 10. 12. 16. 20. 25mm
- [4] Connection female thread type size
*Non by manifold mounting
- [5] O-ring Material: Non-NBR
V-FKM

Circuit diagram

L type flow control valve



LA type flow control check valve

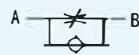

Specifications

Diameter	6	8	10	12	16	20	25
Max. working pressure	31.5MPa						
Max. flow	14	40	60	85	185	200	300
Working medium	Mineral hydraulic oil: Organic phosphate						
Working temperature	-20~70℃						
Cracking pressure	0.05MPa						

General dimensions

1、L Series flow control valve

Circuit diagram

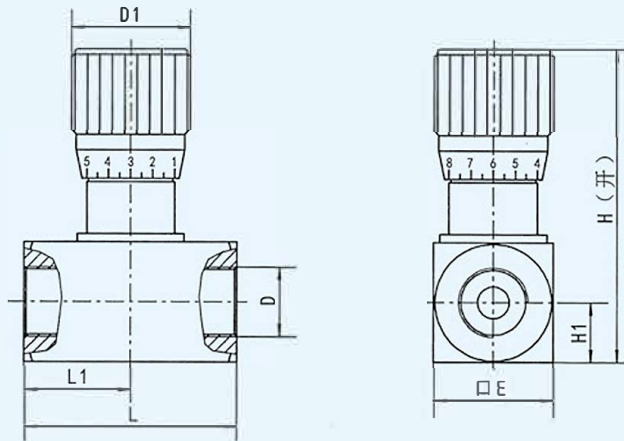

Model	L	L1	D				D1	E	H	H1
L-G6	48	24	M10x1	G1/8	Rc1/8	1/8NPT	30	28	82	14
L-G8	54	27	M14x1.5	G1/4	Rc1/4	1/4NPT	30	28	82	14
L-G10	54	27	M18x1.5	G3/8	Rc3/8	3/8NPT	30	28	82	14
L-G12	68	34	M22x1.5	G1/2	Rc1/2	1/2NPT	38	38	108	19
L-G16	78	39	M27x2	G3/4	Rc3/4	3/4NPT	38	38	108	19
L-G20	92	46	M33x2	G1	Rc1	1NPT	47	48	138	24
L-G25	114	57	M42x2	G1 1/4	Rc1 1/4	1 1/4NPT	47	60	150	30
L-G30	122	61	M48x2	G1 1/2	Rc1 1/2	1 1/2NPT	47	70	160	35



General dimensions

2、LA Series flow control check valve

Circuit diagram

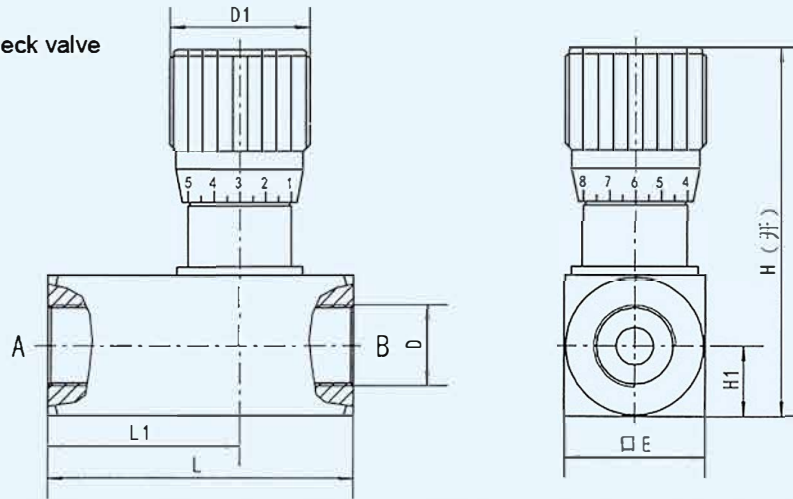
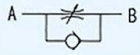

Model	L	L1	D				D1	E	H	H1
LA-G6	58	36	M10x1	G1/8	Rc1/8	1/8NPT	30	28	82	14
LA-G8	64	39	M14x1.5	G1/4	Rc1/4	1/4NPT	30	28	82	14
LA-G10	70	43	M18x1.5	G3/8	Rc3/8	3/8NPT	30	28	82	14
LA-G12	83	52	M22x1.5	G1/2	Rc1/2	1/2NPT	38	38	108	19
LA-G16	89	55.5	M27x2	G3/4	Rc3/4	3/4NPT	38	38	108	19
LA-G20	117	72	M33x2	G1	Rc1	1NPT	47	48	138	24
LA-G25	154	97	M42x2	G1 1/4	Rc1 1/4	1 1/4NPT	47	60	150	30
LA-G30	172	111	M48x2	G1 1/2	Rc1 1/2	1 1/2NPT	47	70	160	35

3、L Series flow control valve for manifold mounting

Circuit diagram

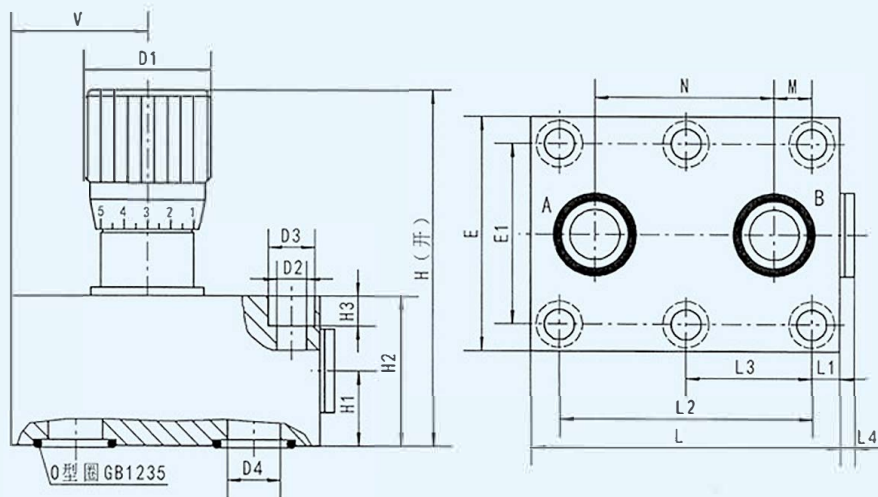

Model	H	H1	H2	H3	D1	D2	D3	D4	E	E1	L	L1	L2	L3	L4	M	N	V	O-ring
L-8	85	11	24	7	30	6.5	10.5	8	46	33.5	48.5	6.8	35	-	3.5	4.5	25.5	24.5	16x2.4
L-10	88	14	28	7	30	6.5	10.5	10	51	38	51	8.5	33.5	-	3.5	4	25.5	25.5	18x2.4
L-12	105	16	35	7	38	6.5	10.5	12	58	44.5	75	18.5	38	-	4.5	4	30	37.5	20x2.4
L-16	123	22.5	45	9	38	9	14	16	70	54	93	8.5	76	38	4.5	11.4	54	41	25x2.4
L-20	151	25	50	9	47	9	14	20	77	60	112	8.5	95	47.5	4.5	19	57	51	30x3.1
L-25	161	30	60	11	47	11	17	25	100	76	144	12	120	60	4.5	20.6	79.5	61	35x3.1
L-30	165	37.5	75	13	47	13	19	30	115	92	173	15	143	71.5	6	23.8	95	73	42x3.1

General dimensions

4、LA Series flow control check valve for manifold mounting

Circuit diagram

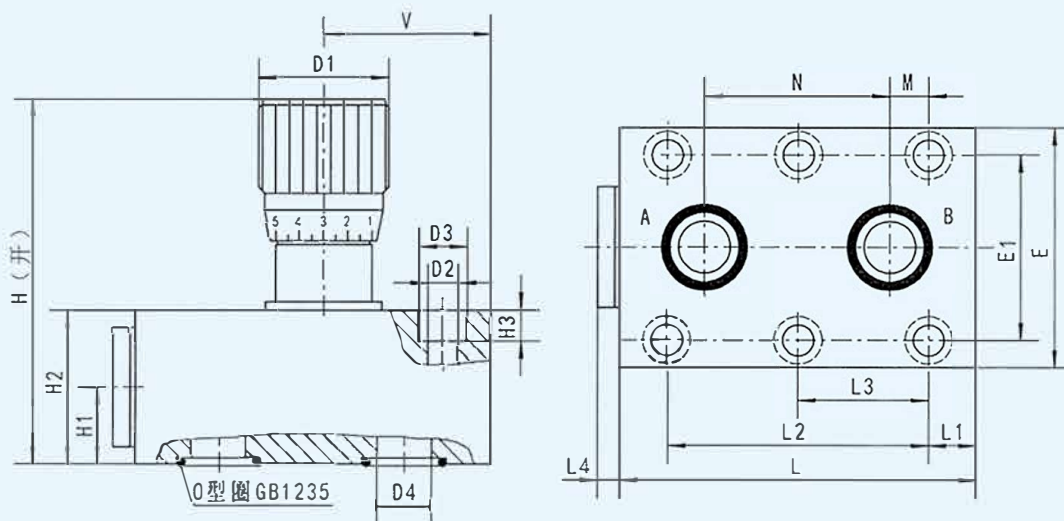
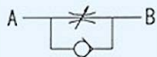

Model	H	H1	H2	H3	D1	D2	D3	D4	E	E1	L	L1	L2	L3	L4	M	N	V	O-ring
LA-8	85	11	24	7	30	6.5	10.5	8	46	33.5	63.5	14	35	-	4.5	4.5	25.5	30	16x2.4
LA-10	88	14	28	7	30	6.5	10.5	10	51	38	70	18	33.5	-	4.5	4	25.5	31	18x2.4
LA-12	105	16	35	7	38	6.5	10.5	12	58	44.5	80	21	38	-	4.5	4	30	36	20x2.4
LA-16	123	22.5	45	9	38	9	14	16	70	54	104	14	76	38	4.5	11.4	54	49	25x2.4
LA-20	151	25	50	9	47	9	14	20	77	60	127	16	95	47.5	6	19	57	49	30x3.1
LA-25	161	30	60	11	47	11	17	25	100	76	165	15	120	60	6	20.6	79.5	77	35x3.1
LA-30	165	37.5	75	13	47	13	19	30	115	92	186	15	143	71.5	6	23.8	95	87	42x3.1

Ordering and Usage Notes

- 1.If you choose "manifold mounting" when making a selection, you can omit the option related to threads in Product Selection Code #4
- 2.Seal material is default as NBR. If you need to change it to FKM, please add "-V" at the end of the Product Selection Code.



How to order

DF3	-	G1/2	-	A	-	S
[1]		[2]		[3]		[4]

- [1] Model: DF3 Plug valve
- [2] Connection Type
- [3] Different Types
- [4] Body and plug material: S-Carbon steel

Circuit diagram

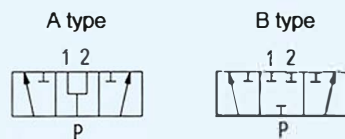

General dimensions

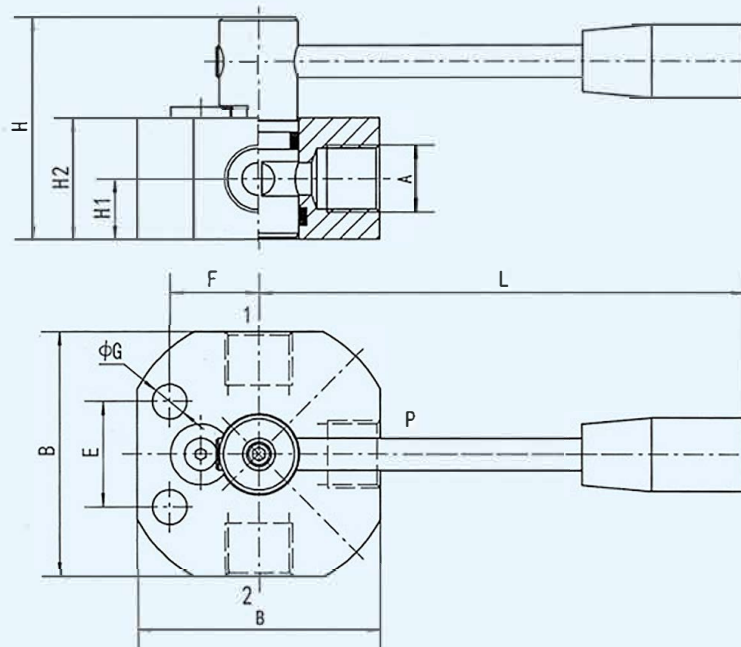

Model	PN	A	B	E	F	G	H	H1	H2	L
DF3-G1/4-※	500	G1/4	60	26	22	8.5	55	15	30	120
DF3-G3/8-※	500	G3/8	60	26	22	8.5	55	15	30	120
DF3-G1/2-※	500	G1/2	65	26	22	8.5	55	15	30	120
DF3-G3/4-※	350	G3/4	80	32	26	11	74	22.5	45	180
DF3-G1-※	350	G1	90	32	31.5	11	74	22.5	45	180



Introduction

The OCUKAC2318 Series Combinations Plug Valve consists of two E-type plug valves combined together and is used in the field of mechanical engineering and agricultural machinery. This valve is resistant to contamination, can withstand a certain degree of pulsation, and features ISO11926-1 SAE standard internal threads for ports. It is compact in size, easy to operate, hose-free, and highly durable.

Technical Parameters

Nominal Pressure: 21 MPa
 Nominal Diameter: 3 mm
 Operating Medium: Mineral Oil
 Handle Travel: 90°

Circuit diagram

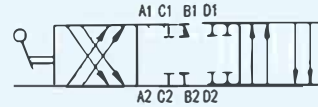

General dimensions

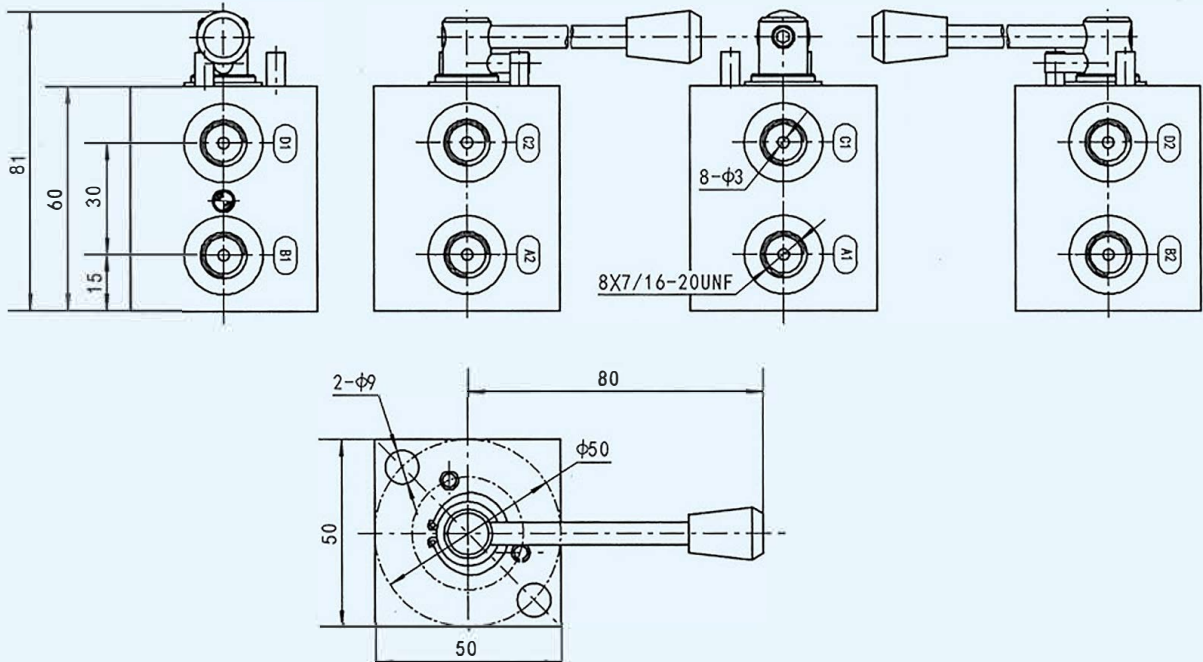



Introduction

Shuttle valve is a type of three-way valve that can be thought of as a combination of two check valves. It compares two input hydraulic signals coming from V1 and V2 and then allows the high-pressure signal to be taken out through the C port.

Function symbol

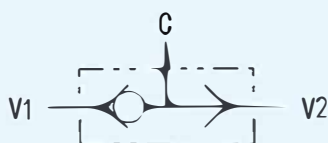

Technical Parameters

Model	Maximum pressure (MPa)	Maximum flow (L/min)
VUSF-G1/4	35	20
VUSF-G3/8	35	45
VUSF-G1/2	35	80
VUSF-G3/4	35	110
VUSF-G1	31.5	150

General dimensions

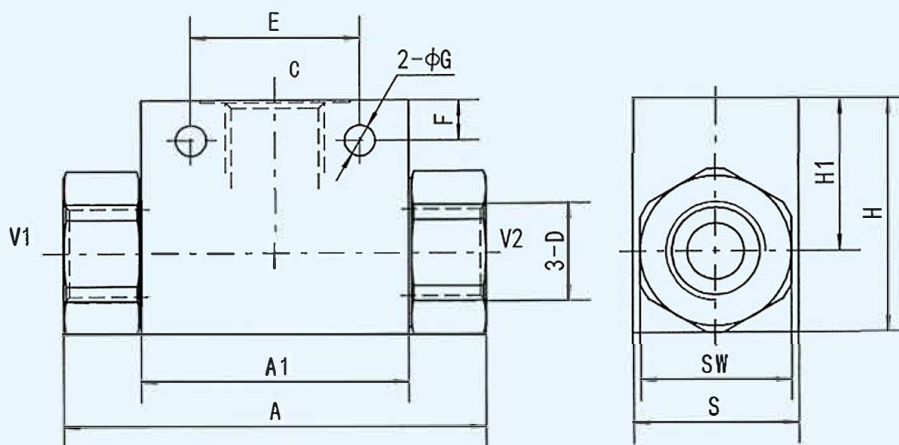

Model	A	A1	D	E	F	G	H	H1	S	SW
VUSF-G1/4	51	36	G1/4	25	9.5	5.5	40	27.5	25	22
VUSF-G3/8	59	45	G3/8	29	8	6.5	45	30	30	27
VUSF-G1/2	90	57	G1/2	36	8.5	6.5	50	32.5	35	32
VUSF-G3/4	113	62	G3/4	50	6.5	8.5	60	37	45	41
VUSF-G1	120	80	G1	60	11	10.5	80	54.5	50	46



Introduction

VBPSE single pilot operated check valves are commonly used to block hydraulic cylinders in one direction, allowing fluid to flow in one direction while blocking it in the reverse direction. When there is pilot pressure oil, fluid can flow in the reverse direction.

Application

V1 and V2 are connected to the hydraulic pressure, while C1 and C2 are connected to the actuator.

Circuit diagram

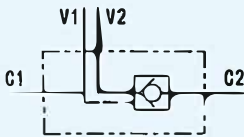

Technical Parameters

Specification	1/4L	3/8L	1/2L	3/8	1/2	3/4
Power ratio	1:5.5	1:5.5	1:5	1:5	1:4	1:4
Max flow(L/min)	20	35	50	45	70	100
Max pressure(bar)	350	350	350	350	350	300
Opening pressure(bar)	4	3	6	8	3.5	2

General dimensions

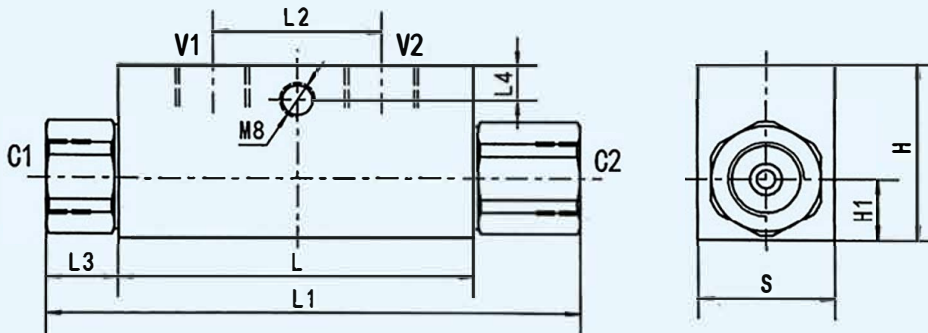

Model	V1-V2 /C1-C2	L	L1	L2	L3	L4	H	H1	S
VBPSE-1/4L	G1/4	64	106.5	36	18	8	40	14	30
VBPSE-3/8L	G3/8	80	120	38	16	8	40	14	30
VBPSE-1/2L	G1/2	90	133	45	17	12.5	45	15	35
VBPSE-3/8	G3/8	90	148	45	25	12.5	45	15.5	35
VBPSE-1/2	G1/2	80	134	40	22	18	60	20	35
VBPSE-3/4	G3/4	100	182	46	36	12	60	20	40

Pressure drop curve

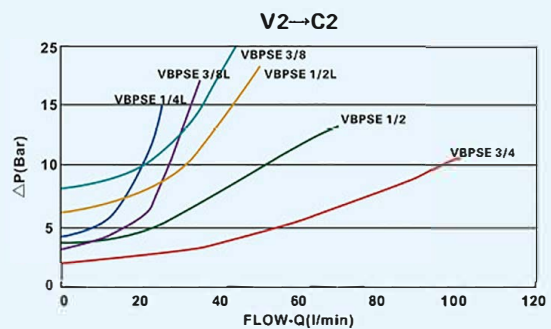
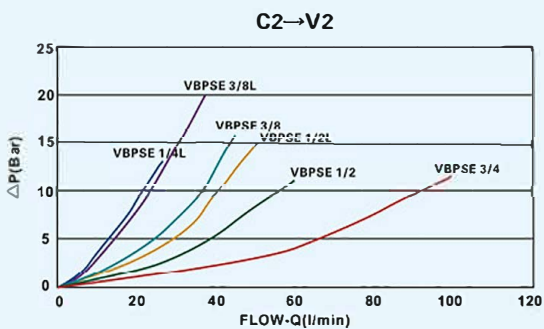



Introduction

VBPDE double pilot operated check valves are commonly used for double-acting hydraulic cylinders, allowing fluid to flow in one direction and blocking it in the reverse direction. When there is pilot pressure oil, fluid can flow in the reverse direction.

Application

V1 and V2 are connected to the hydraulic pressure, while C1 and C2 are connected to the actuator.

Circuit diagram

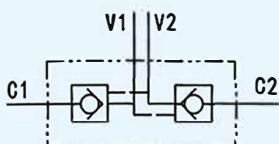

Technical Parameters

Specification	1/4L	3/8L	1/2L	18L	3/8	1/2	3/4
Power ratio	1:5.5	1:5.5	1:5	1:5.5	1:5	1:4	1:4
Max flow(L/min)	20	35	50	35	45	70	100
Max pressure(bar)	350	350	350	350	350	350	300
Opening pressure(bar)	4	3	6	4	8	3.5	2

General dimensions

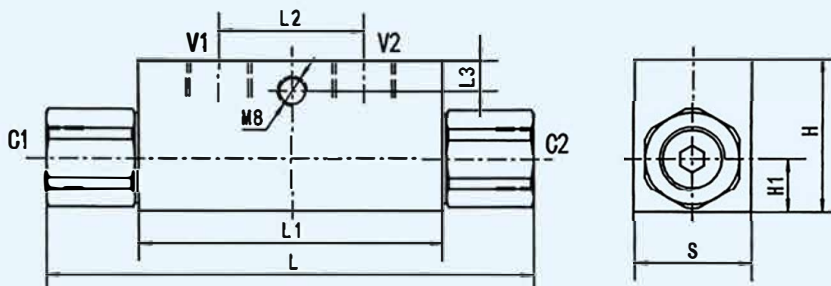

Model	V1-V2 /C1-C2	L	L1	L2	L3	H	H1	S
VBPDE-1/4L	G1/4	113	64	36	8	40	14	30
VBPDE-3/8L	G3/8	128	80	38	8	40	14	30
VBPDE-1/2L	G1/2	142	90	45	12.5	45	15	35
VBPDE-18L	M18×1.5	118	68	38	8	40	14	30
VBPDE-3/8	G3/8	156	90	45	12.5	45	15.5	35
VBPDE-1/2	G1/2	144	80	40	18	60	20	35
VBPDE-3/4	G3/4	192	100	46	12	60	20	40

Pressure drop curve

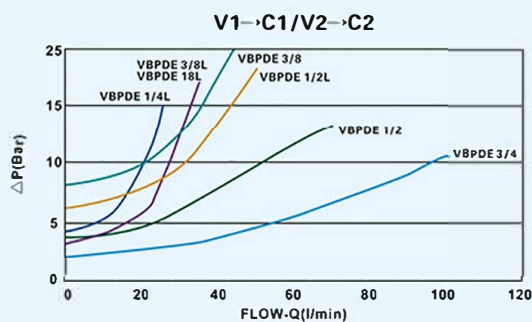
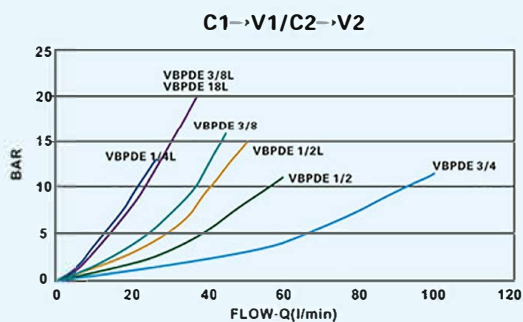



Introduction

Single Pilot Operated Check Valve is commonly used to unidirectionally block hydraulic cylinders, allowing fluid to flow in one direction while blocking it in the reverse direction. When there is a pilot pressure, fluid can flow in the reverse direction.

Application

V1 and V2 are connected to the pressure oil, C1 and C2 are connected to the actuator.

Circuit diagram

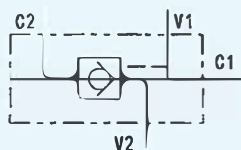

Technical Parameters

Model	Power ratio	Max flow	Max pressure	Opening pressure
VBPSE-1/4FL	1:8	20L/min	350bar	4.5bar
VBPSE-3/8FL	1:8	30L/min	350bar	4.5bar
VBPSE-1/2FL	1:4.5	55L/min	350bar	5.5bar

General dimensions

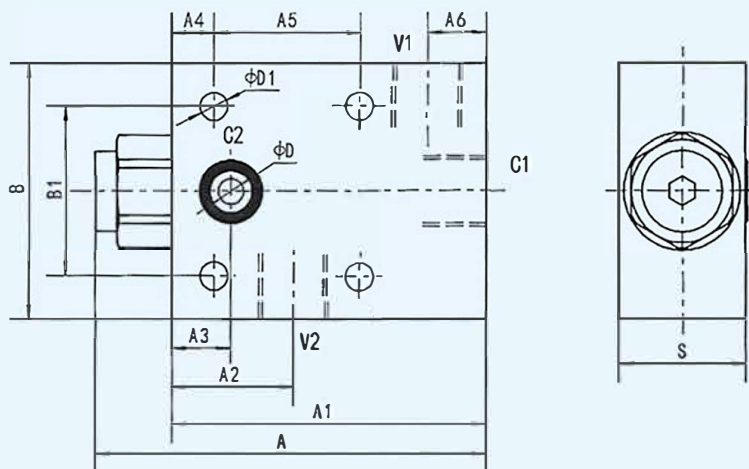

Model	V1-V2-C1	A	A1	A2	A3	A4	A5	A6	B	B1	D	D1	S
VBPSE-1/4FL	G1/4	74.5	70	27	15.5	6.5	35	13	50	35	5	6.5	30
VBPSE-3/8FL	G3/8	93	75	29	14	10	35	14	60	40	6.5	6.5	30
VBPSE-1/2FL	G1/2	117.5	100	32	18	10.5	40	18	80	40	9	8.5	35

Pressure drop curve

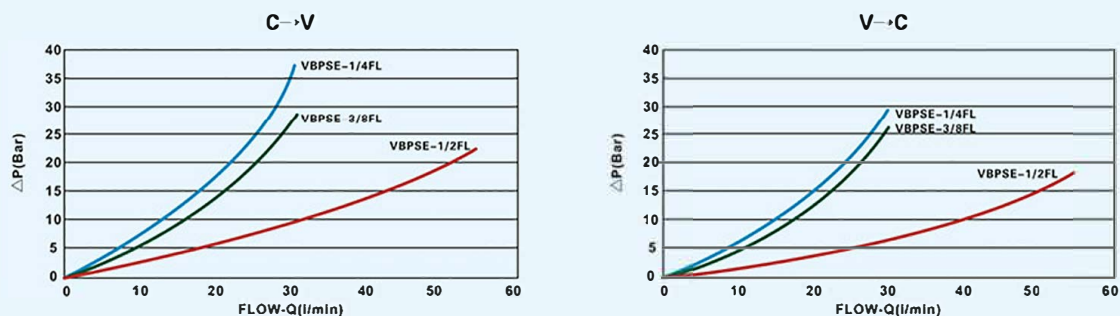



Introduction

Double Pilot Operated Check Valve is commonly used to unidirectionally block hydraulic cylinders, allowing fluid to flow in one direction while blocking it in the reverse direction. When there is a pilot pressure, fluid can flow in the reverse direction

Application

V1 and V2 are connected to the pressure oil, C1 and C2 are connected to the actuator.

Circuit diagram

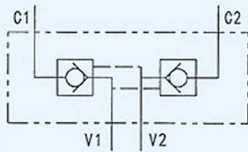

Technical Parameters

Model	Power ratio	Max flow	Max pressure	Opening pressure
VBPDE-3/8FL	1:5.5	30L/min	350bar	4.5bar
VBPDE-1/2FL	1:4.5	55L/min	350bar	5.5bar

General dimensions

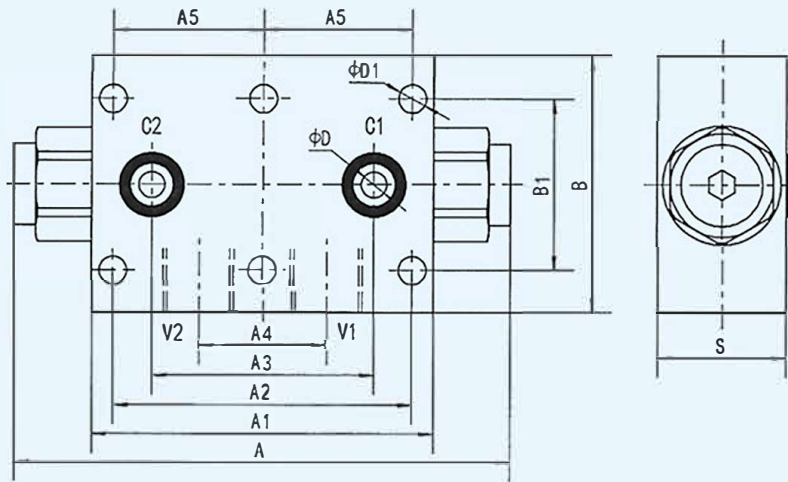

Model	V1-V2	A	A1	A2	A3	A4	A5	B	B1	D	D1	S
VBPDE-3/8FL	G3/8	116	80	70	52	30	35	60	40	6	6.5	30
VBPDE-1/2FL	G1/2	150	115	81	81	39	/	80	56	11	8.5	35

Pressure drop curve

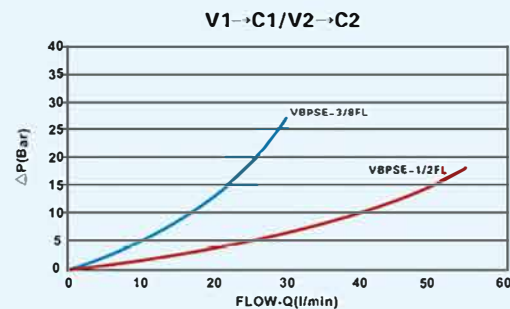
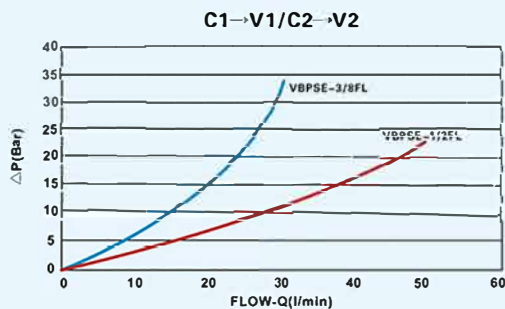

Pilot Operated Check Valve For Double Acting Cylinder



Introduction

Double Pilot Operated Check Valve is commonly used to unidirectionally block hydraulic cylinders, allowing fluid to flow in one direction while blocking it in the reverse direction. When there is a pilot pressure, fluid can flow in the reverse direction.

Application

V1 and V2 are connected to the pressure oil, C1 and C2 are connected to the actuator.

Circuit diagram

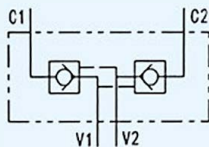

Technical Parameters

Model	Power ratio	Max flow	Max pressure	Opening pressure
VBPDC-G3/8	1:5.5	30L/min	350bar	4.5bar
VBPDC-G1/2	1:4.5	55L/min	350bar	5.5bar

General dimensions

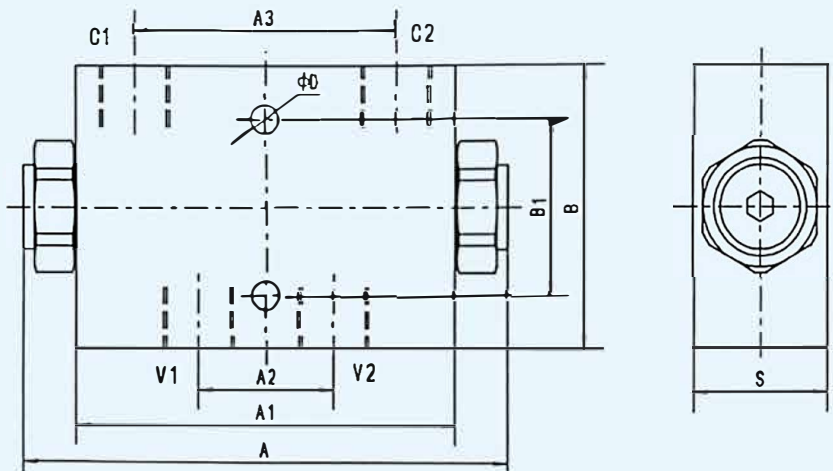

Model	V1-V2/ C1-C2	A	A1	A2	A3	B	B1	D1	S
VBPDC-G3/8	G3/8	113	80	30	52	60	44	8.5	30
VBPDC-G1/2	G1/2	149	115	39	80	80	40	8.5	35

Pressure drop curve

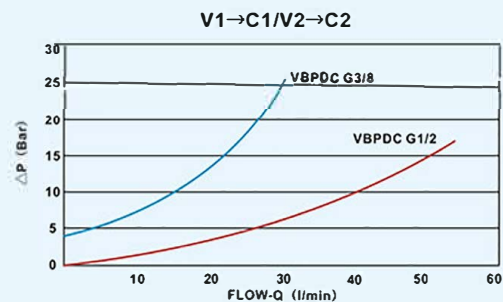
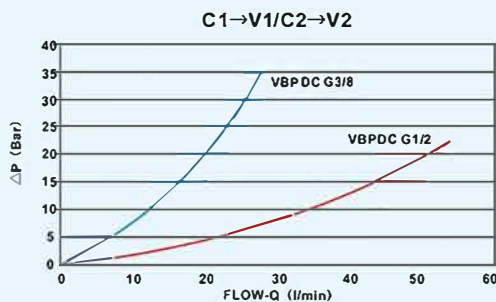

Pilot Operated Check Valve For Single Acting Cylinder



Introduction

Single Pilot Operated Check Valve is commonly used to unidirectionally block hydraulic cylinders, allowing fluid to flow in one direction while blocking it in the reverse direction. When there is a pilot pressure, fluid can flow in the reverse direction.

Circuit diagram

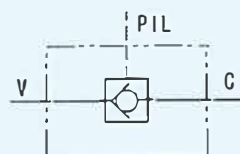

General dimensions

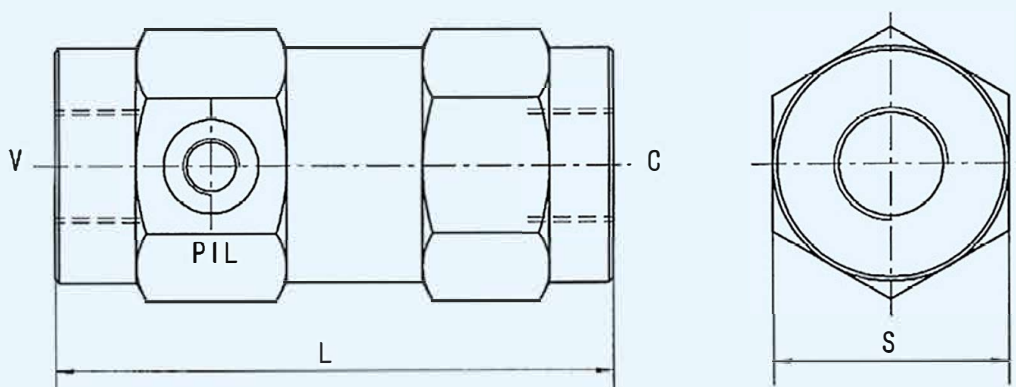

Model	V-C	PIL	A	S	Max flow (L/min)	Max pressure (bar)	Power ratio
VRPE-G1/4	G1/4	G1/4	102	40	25	350	1 3.6
VRPE-G3/8	G3/8	G1/4	108	41	40	350	1 3.2
VRPE-G1/2	G1/2	G1/4	120	42	60	350	1 2.8
VRPE-G3/4	G3/4	G1/4	131	55	100	300	1 3.2
VRPE-G1	G1	G1/4	170	60	150	300	1 6.2

Pressure drop curve

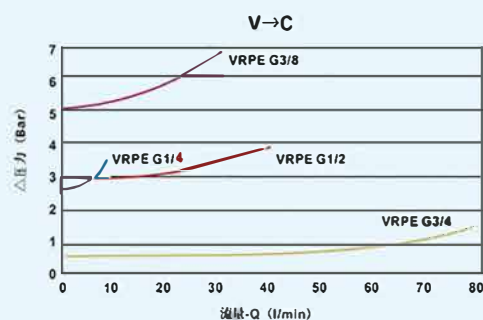
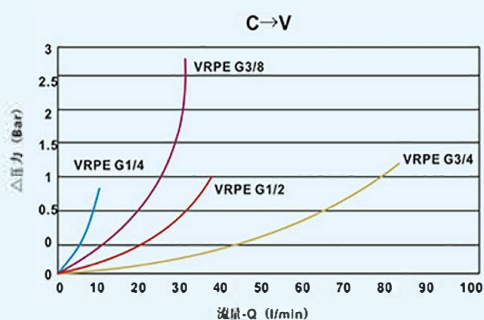



How to order

VBSO-SE	10	G	G
[1]	[2]	[3]	[4]

- [1] Model: VBSO-SE Single counterbalance valve
VBSO-DE Double counterbalance valve
- [2] Diameter: 6、10、15mm
- [3] Connection type: G-Din ISO 228 thread
P1-1 Ports Manifold Mounting
P2-2 Ports Manifold Mounting
M- superposition
- [4] Thread standard: G-Din ISO 228
M-JB984-77

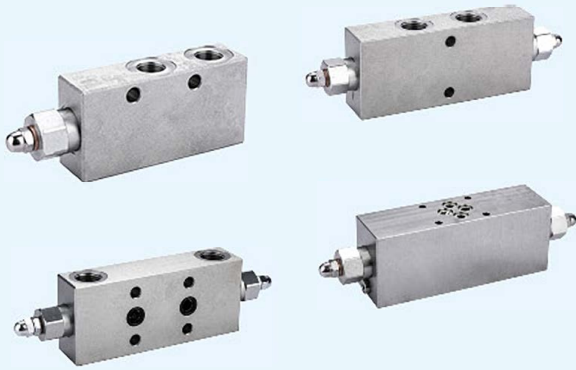

Circuit diagram

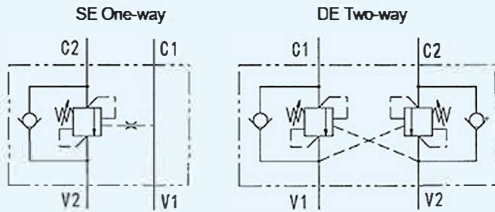

Technical Parameters

Model	Power ratio	Max flow	Max pressure	Opening pressure
VBSO-※-6※	1: 4.2	30L/min	350bar	4.5bar
VBSO-※-10※	1: 4.2	40L/min	350bar	4.5bar
VBSO-※-15※	1: 4.2	60L/min	320bar	5.5bar

General dimensions

VBSO-SE-※G

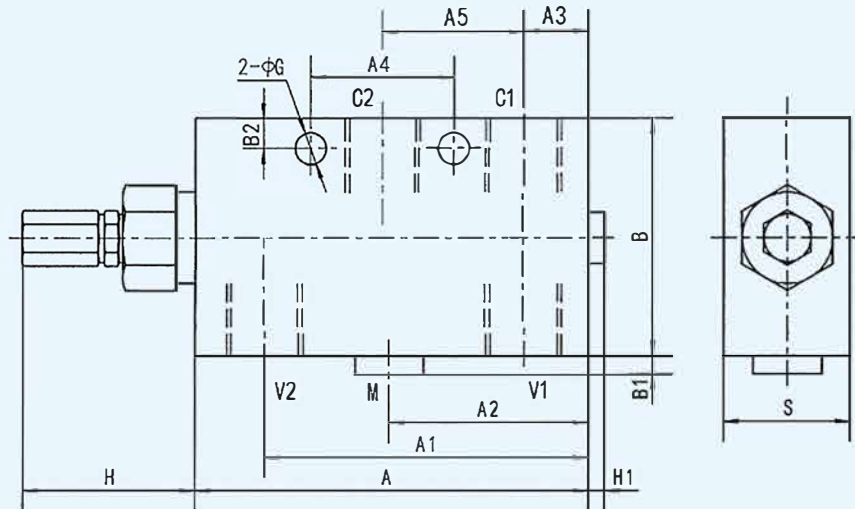

Model	V1-V2	C1-C2	A	A1	A2	A3	A4	A5	B	B1	B2	G	H	H1	S
VBSO-SE-6G	G1/4	M14×1.5	109	88.3	/	18	40	39.3	55	/	8	8.5	47.5	4.5	30
VBSO-SE-10G	G3/8	M18×1.5	109	88.3	/	18	40	39.3	55	/	8	8.5	47.5	4.5	30
VBSO-SE-15G	G1/2	M22×1.5	109	89.8	55.3	18	40	39.3	65	5	8	8.5	47.5	4.5	35



General dimensions

VBSO-DE-※G

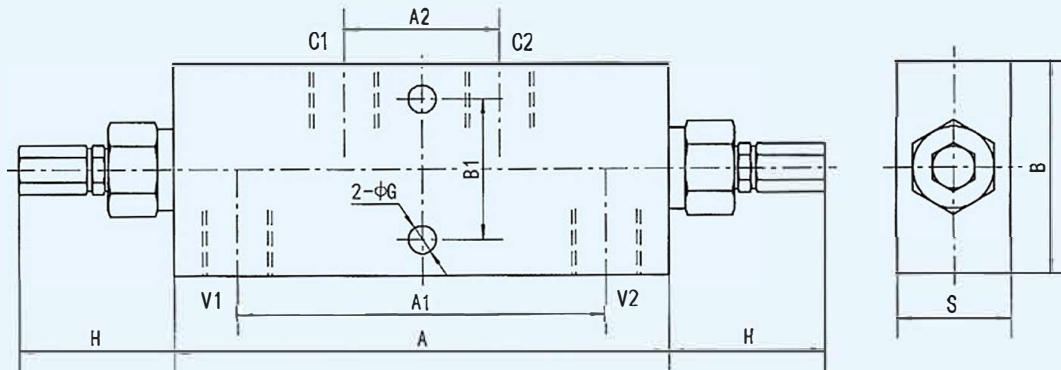

Model	V1-V2	C1-C2	A	A1	A2	B	B1	G	H	S
VBSO-DE-6G	G1/4	M14×1.5	151	109.6	47.6	55	38	8.5	47.5	30
VBSO-DE-10G	G3/8	M18×1.5	151	109.6	47.6	55	38	8.5	47.5	30
VBSO-DE-15G	G1/2	M22×1.5	151	112.6	47.6	65	43	8.5	47.5	35

VBSO-SE-※P1

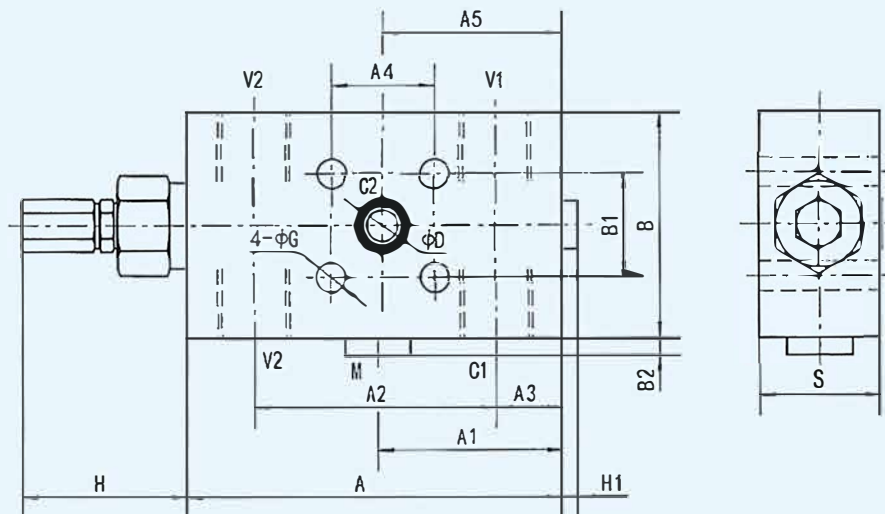

Model	V1-V2	C1-C2	A	A1	A2	A3	A4	A5	B	B1	B2	D	G	H	H1	S
VBSO-SE-6P1	G1/4	M14×1.5	109	51.7	70.3	20.7	30	51.7	55	30	5	9	8.5	47.5	4.5	30
VBSO-SE-10P1	G3/8	M18×1.5	109	51.7	70.3	20.7	30	51.7	55	30	5	9	8.5	47.5	4.5	30
VBSO-SE-15P1	G1/2	M22×1.5	109	53.7	70.3	19.2	30	52	65	30	5	9	8.5	47.5	4.5	35



General dimensions

VBSO-SE-※P2

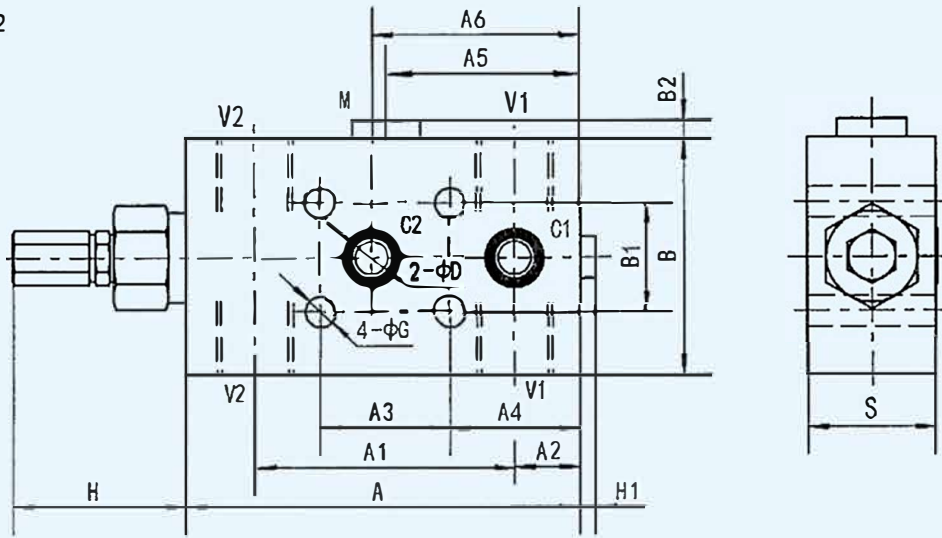

Model	V1-V2	C1-C2	A	A1	A2	A3	A4	A5	A6	B	B1	B2	D	G	H	H1	S
VBSO-SE-6P2	G1/4	M14×1.5	109	71.5	18	36	36	0	57	55	30	0	9	8.5	47.5	4.5	30
VBSO-SE-10P2	G3/8	M18×1.5	109	71.5	18	36	36	0	57	55	30	0	9	8.5	47.5	4.5	30
VBSO-SE-15P2	G1/2	M22×1.5	109	72	18	36	36	56	57.5	65	30	3	9	8.5	47.5	4.5	35

VBSO-DE-※P2

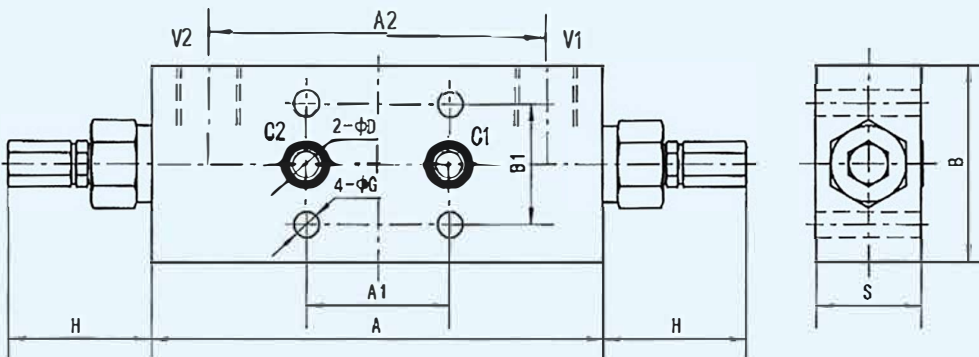

Model	V1-V2	C1-C2	A	A1	A2	B	B1	D	G	H	S
VBSO-DE-6P2	G1/4	M14×1.5	151	48	110	55	40	9	8.5	47.5	30
VBSO-DE-10P2	G3/8	M18×1.5	151	48	110	55	40	9	8.5	47.5	30
VBSO-DE-15P2	G1/2	M22×1.5	151	48	113	65	40	9	8.5	47.5	35



General dimensions

VBSO-DE-6M

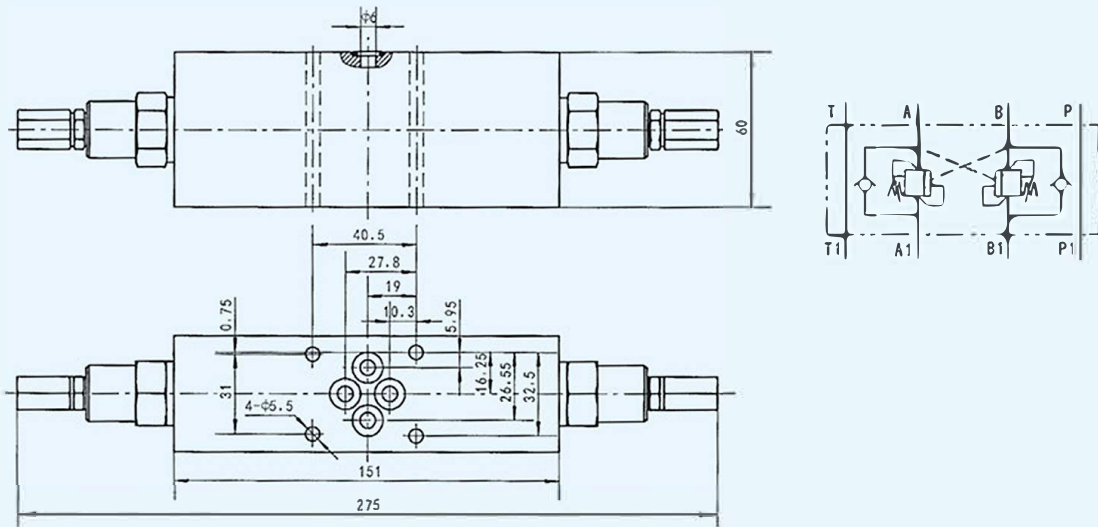

Pressure drop curve

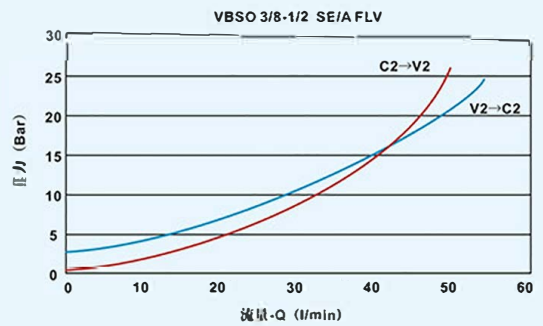
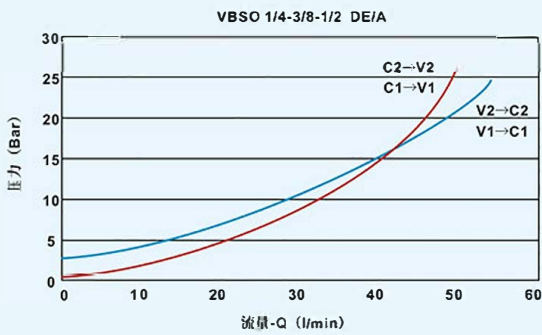

Double Overcenter Valves Fixing By Screw



Technical Parameters

Model	Max pressure (bar)	Max flow (L/min)	Power ratio
VBCD-G3/8-DE-FLV	350	40	1: 4.5
VBCD-G1/2-DE-FLV	350	60	1: 4.5

Circuit diagram

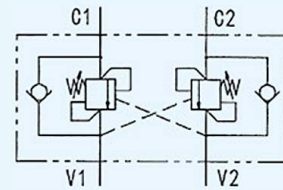

General dimensions

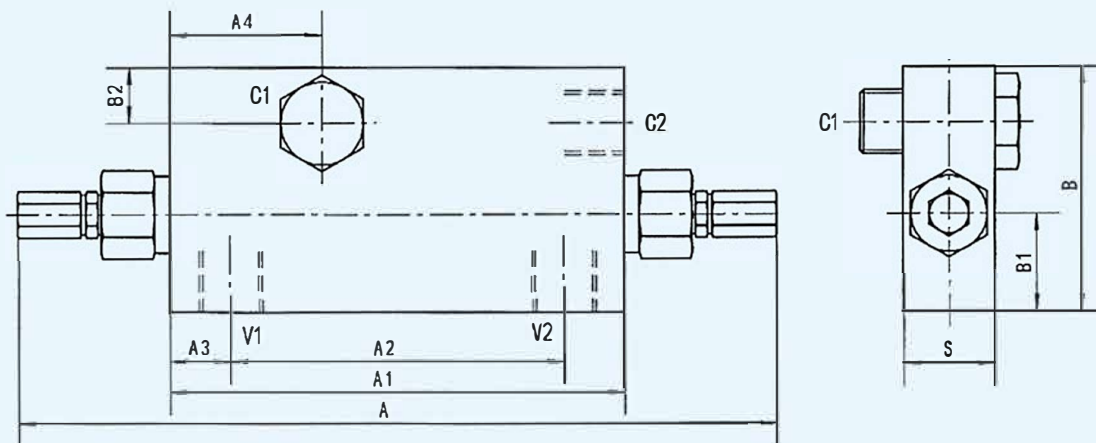

Model	V1-V2 C1-C2	A	A1	A2	A3	A4	B	B1	B2	S
VBCD-G3/8-DE-FLV	G3/8	250	150	110	20	50	70	30	12.5	30
VBCD-G1/2-DE-FLV	G1/2	250	150	110	20	50	80	32	18	30



Introduction

The adaptor is connected to a pressure testing device or pressure gauges for testing the pressure in the hydraulic system.

Specifications

- [1] Nominal diameter: 3mm
- [2] Max. working pressure: 40MPa

General dimensions

1.PT and PPT series pressure testing adaptor with gasket seal

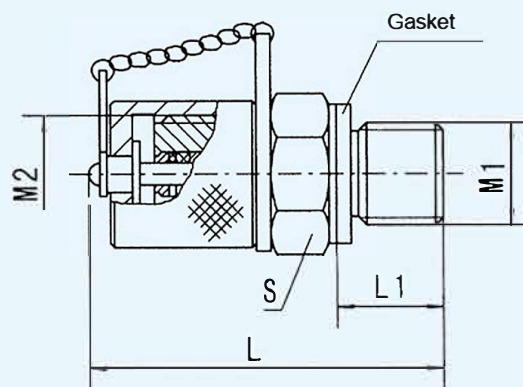

PT Series Pressure Testing Adaptors (without air venting function)

Model	Original model	M1	M2	L	L1	S	Hose adaptor type
PT-1	PT-00	M10×1	M12×1.25	33	8	17	H1
PT-2	PT-00A1	M10×1	M16	46	10	19	H2
PT-3	PT-00A1/DI-3/M14×1.5	M14×1.5	M16	46	12	19	H2
PT-4	DI-3/M10×1	M10×1	M16	46	10	19	H2
PT-5	DI-3/M12×1.5	M12×1.5	M16	46	12	19	H2
PT-6	DI-3/M18×1.5	M18×1.5	M16	46	12	24	H2
PT-7	DI-3/G1/4	G1/4	M16	46	12	19	H2
PT-8	BZ	M12×1.5	M14×1.5	50	12	17	H3
PT-9	KF-1/M10×1	M10×1	M16×1.5	46	11.5	19	H4
PT-10	KF-1/M12×1.5	M12×1.5	M16×1.5	46	11.5	19	H4
PT-11	KF-1/M14×1.5	M14×1.5	M16×1.5	46	11.5	19	H4
PT-12	KF-1/M18×1.5	M18×1.5	M16×1.5	46	11.5	24	H4

PPT Series Pressure Testing Adaptors (with air venting function)

Model	Original model	M1	M2	L	L1	S	Hose adaptor type
PPT-1	PT1-00	M10×1	M12×1.25	33	10	17	H1
PPT-2	PT1-00A1	M10×1	M16	46	10	19	H2
PPT-3	PT1-00A2	M14×1.5	M16	46	12	19	H2
PPT-5		M12×1.5	M16	46	12	19	H2

PT Series Pressure Testing Adaptors with ED ring seal (without air venting function)

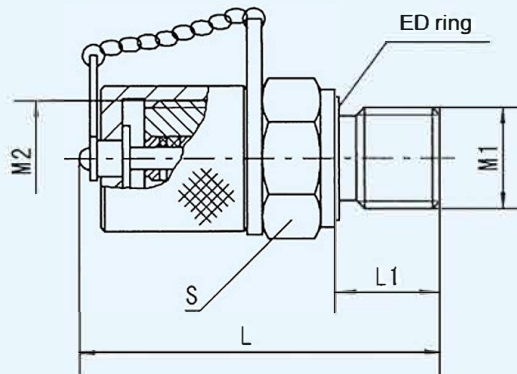

Model	M1	M2	L	L1	S	Hose adaptor type
PT-21	M10×1	M16	46	8	19	H2
PT-22	G1/4	M16	46	12	19	H2
PT-23	M14×1.5	M16	46	12	19	H2

Size matched with adaptor

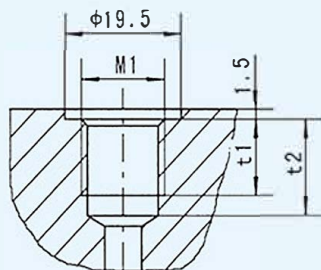

Model	M1	t1	t2
PT-21	M10×1	10	13
PT-22	G1/4	13	16
PT-23	M14×1.5	13	16

PT Series Pressure Testing Adaptors with O ring seal (without air venting function)

Size matched with adaptor

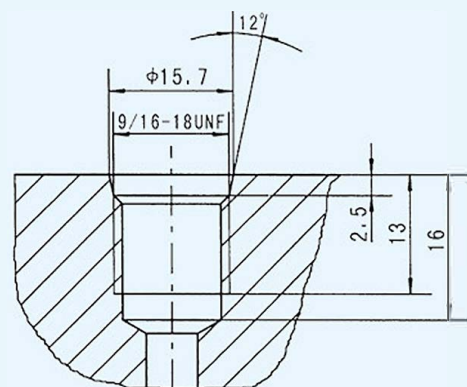
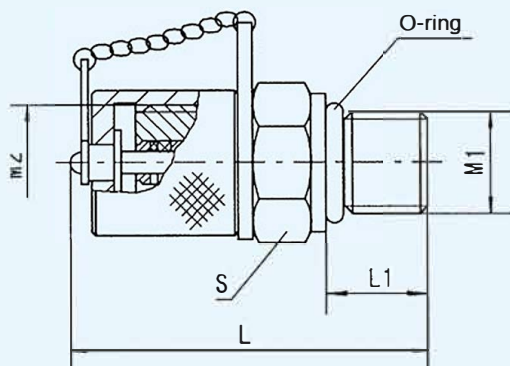

Model	M1	M2	L	L1	S	Hose adaptor type
DI-3	9/16-18UNF	M16	46	12	19	H2

Notes: Accept size customization and modification



How to order



HF	X	X	-	X	X	-	X	P	X
[1]	[2]	[3]		[4]	[5]		[6]	[7]	[8]

[1] Mini high pressure hose adaptor assembly

[2] Connecting type of another end:

- J: Adjustable fitting
- O: Cone seal fitting
- H: Quick fitting
- P: Direct connect to pressure gauge
- K: Tube jam fitting
- G: Outor fixed thread
- S: Snap-check fitting
- E: Outer thread

[3] Connecting thread of another end

- J, K, O type-1: M10x1
2: M14x1.5
- P, S type-1: M14x1.5
2: M20x1.5
3: G1/4
- H type-1: M12*1.25
2: M16
3: M14x1.5
4: M16x1.5
- G type-1: M12*1.25
2: M14x1.5
3: M16x1.5
- E type-1: M14*1.5
2: G1/4

[4] Connecting type of another end

- J: Adjustable fitting
- O: Cone seal fitting
- H: Quick fitting
- P: Direct connect to pressure gauge
- K: Tube jam fitting
- G: Outor fixed thread
- S: Snap-check fitting
- E: Outer thread

[5] Connecting thread of another end

- J, K, O type-1: M10x1
2: M14x1.5
- P, S type-1: M14x1.5
2: M20x1.5
3: G1/4
- H type-1: M12*1.25
2: M16
3: M14x1.5
4: M16x1.5
- G type-1: M12*1.25
2: M14x1.5
3: M16x1.5
- E type-1: M14*1.5
2: G1/4

[6] Nominal diameter. 3mm

[7] Pressure class: P-40MPa

[8] Length of hose unit

Hose assembly diagram

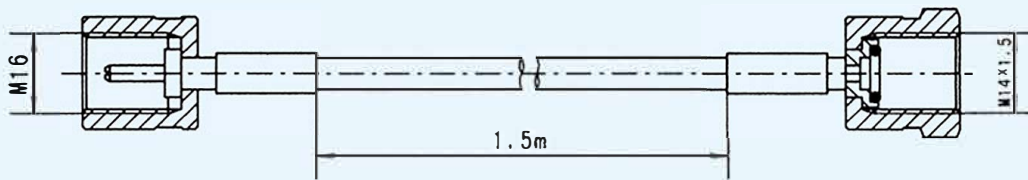



General dimensions

1. Adjustable fitting: HF J※ Unit: mm

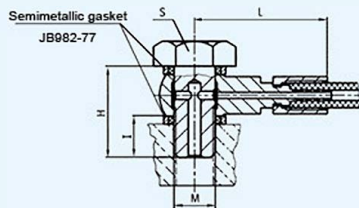

J※	M	S	I	H	L	组合垫圈
J1	M10X1	17	10	22	33	10
J2	M14X1.5	19	14	26	40	14

2. Cone seal fitting: HF O※ Unit: mm

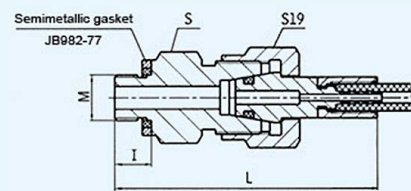

O※	M	I	L	S	组合垫圈
O1	M10X1	8	54	17	10
O2	M14X1.5	12	58	19	14

3. Quick fitting: HF H※ Unit: mm

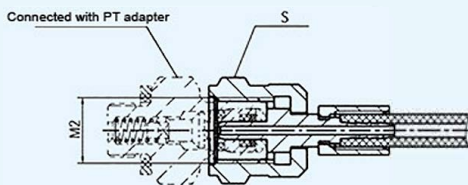

H※	M2	S
H1	M12X1.25	17
H2	M16	19
H3	M14X1.5	17
H4	M16X1.5	19

4. Direct connect to pressure gauge: HF P※ Unit: mm

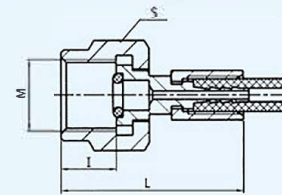

P※	M	S	L	I
P1	M14X1.5	17	34	10
P2	M20X1.5	24	42	18
P3	G1/4	17	34	10
P4	G1/2	27	35	11

5. Tube jam fitting: HF K※ Unit: mm

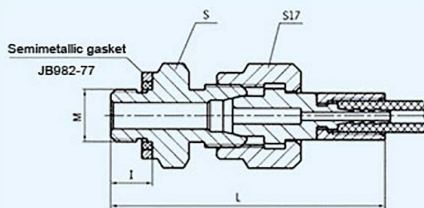

K※	M	I	L	S	组合垫圈
K1	M10X1	8	51	17	10
K2	M14X1.5	12	55	19	14

6. Outer fixed thread: HF G※ Unit: mm

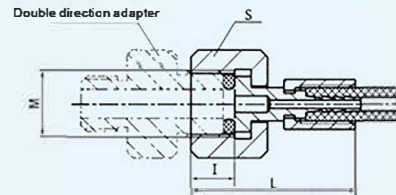

G※	M	S	L	I
G1	M12X1.25	17	8	31
G2	M14X1.5	17	10	33
G3	M16X1.5	19	10	33

7. Snap-check fitting: HF S※ Unit: mm

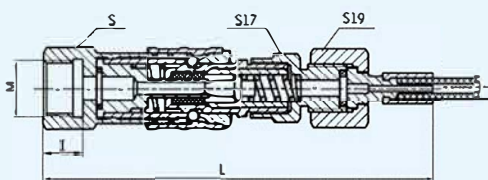

S※	M	S	L	I
S1	M14X1.5	12	104	19
S2	M20X1.5	14	106	24
S3	G1/4	12	104	19

8. Outer thread: HF E※ Unit: mm

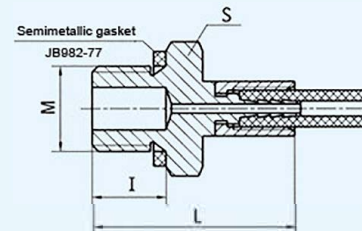

E※	M	S	L	I
E1	M14X1.5	12	34	19
E2	G1/4	12	34	19



Introduction

The CDZ-D3 nitrogen charging cart is a specialized booster device used for charging and pressurizing NXQ series bladder accumulators, piston accumulators, diaphragm accumulators, and other high-pressure containers with nitrogen gas.

How to order

CDZ	-	※	D3	-	※L
[1]		[2]	[3]		[4]

[1] Model: CDZ-D3 nitrogen charging cart

[2] Max charging pressure: 25, 35MPa

[3] Commutation mode: electromagnetic commutation type

[4] Inflation capacity: 2.5L

Working Principle

This type of nitrogen charging cart consists of a hydraulic system, pneumatic system, and electrical control system. When hydraulic fluid enters the oil inlet chamber of the boosting cylinder through the solenoid directional valve and drives the piston's movement, nitrogen gas enters the boosting cylinder. It then flows through a check valve and the inflation tool into the accumulator (high-pressure container). Simultaneously, the boosting cylinder undergoes reciprocating motion through the action of a sensor. When the nitrogen is pressurized to the required working pressure, the system will automatically shut down.

Specification

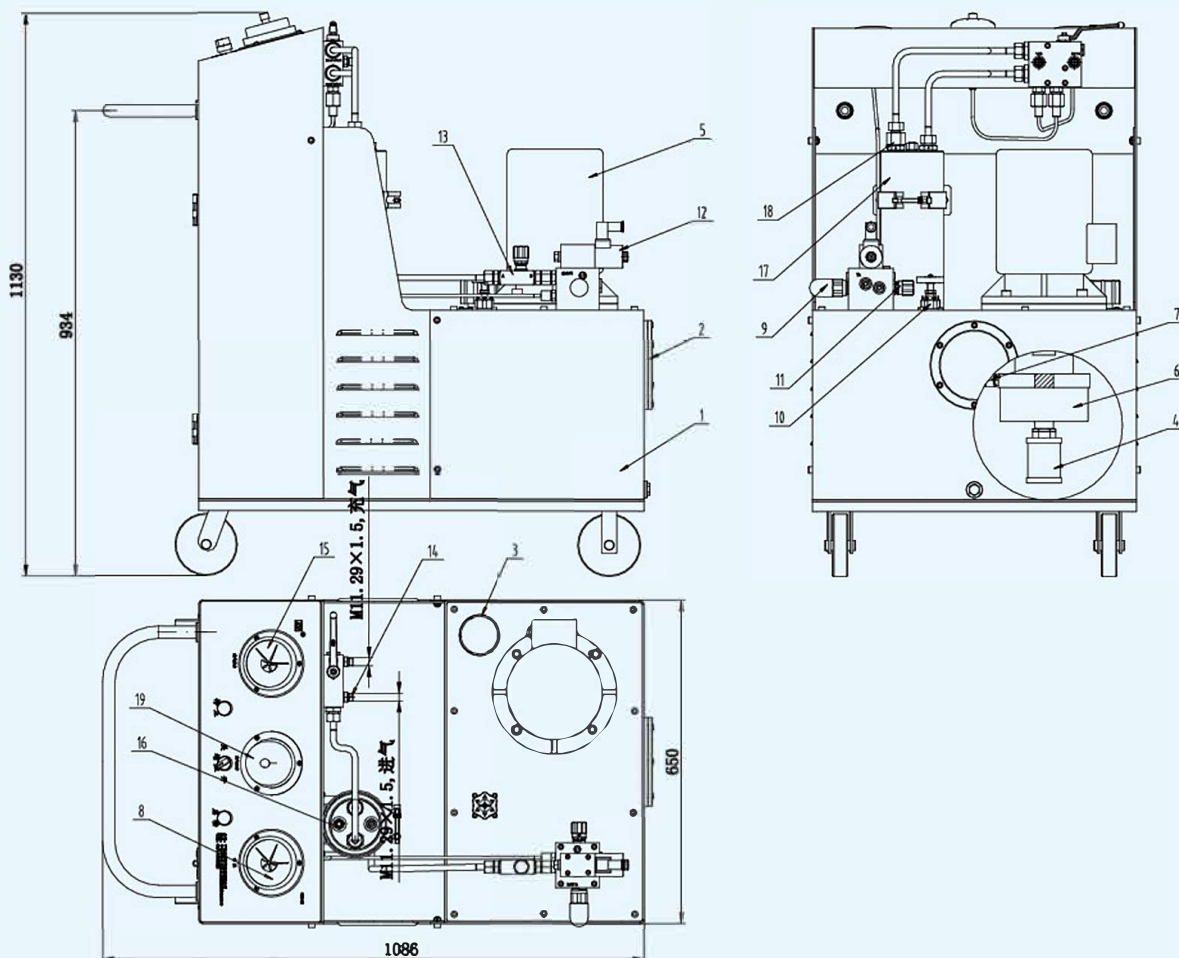



Specification

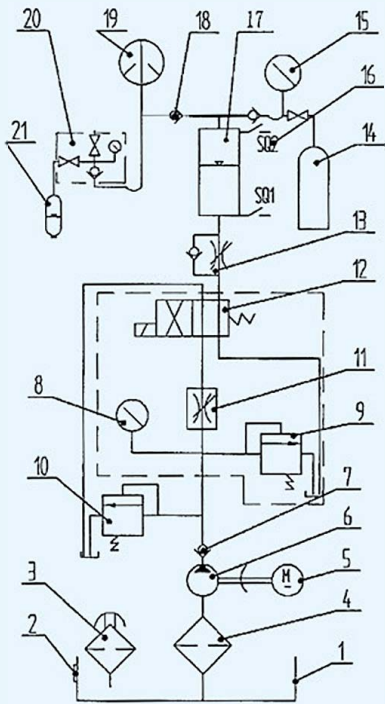

- 1. Oil Tank
- 2. Liquid level gauge
- 3. Air filter
- 4. Filter
- 5. Electric motor
- 6. Hydraulic pump
- 7. Check valve
- 8. Hydraulic Pressure gauge
- 9. Safety valve
- 10. Overflow valve
- 11. Throttle valve
- 12. Electromagnetic directional valve
- 13. Throttle check valve
- 14. Nitrogen cylinder
- 15. Intake pressure gauge
- 16. Sensors
- 17. Booster cylinder
- 18. Inflation check valve
- 19. Electric contact pressure gauge
- 20. Inflation tool
- 21. Accumulator

Model	Intake pressure (MPa)	Max.output pressure (MPa)	Oil pump		Inflation volume (L)	Power supply	Overall dimension Length x width x height	Weight (kg)
			(MPa)	(L/min)				
CDZ-25D3-2.5L	3~13.5	25	31.5	5.37	2.5	3-phase 380V 50HZ	1086 x 650 x 1130	240
CDZ-35D3-2.5L		32	50	6.26				245

Ordering and Usage Notes

- (1) If you have any special requirements for the nitrogen charging cart, please contact us.
- (2) For new products with undefined external design, we reserve the right to make design changes without further notice.



Introduction

FPU Multi-function Inflatable kit is used to accumulator for charging or checking pressure.

How to order

FPU	-	40	-	JT1	-	K
[1]		[2]		[3]		[4]

- [1] Model: FPU Multi-function Inflatable kit
 [2] Pressure setting: 16-16MPa25-25MPa40-40MPa
 [3] Adapter: JT1-7/8-14UNF JT2-5/8-18UNF
 JT3-5/16-32UNF JT4-M14x1.5
 JT5-M16x2 JT6-5/8-18UNF
 JT7-7/8-14UNF Non-Without Adapter
 [4] Kit box: K-With box Non-Without box



General dimensions

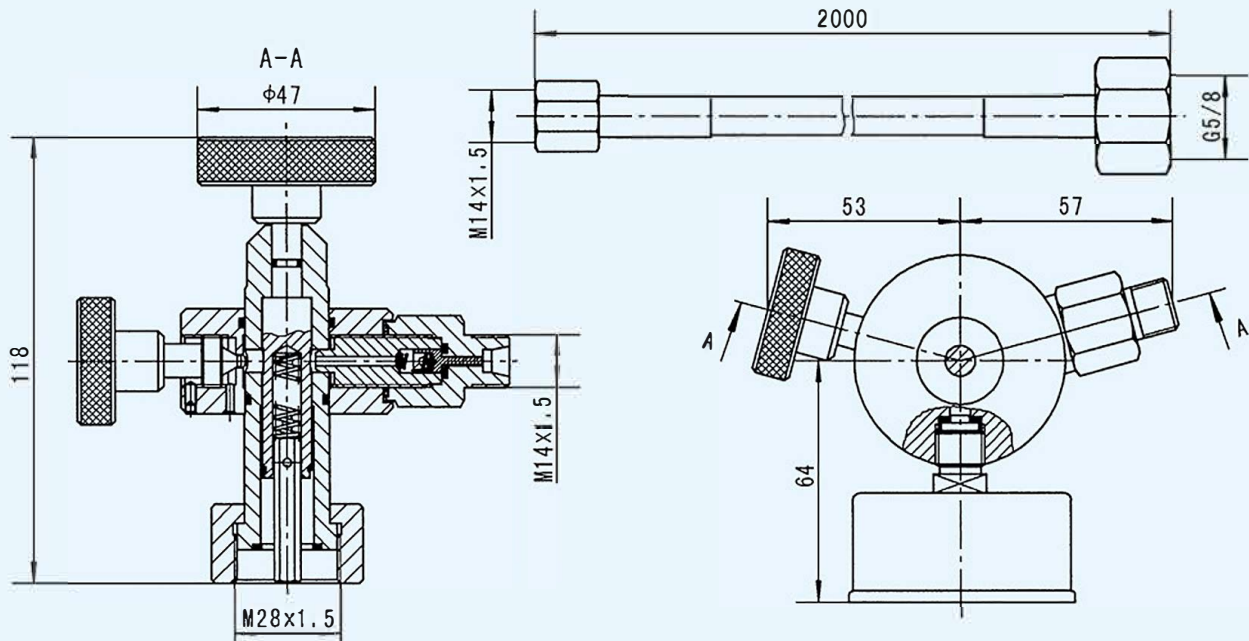

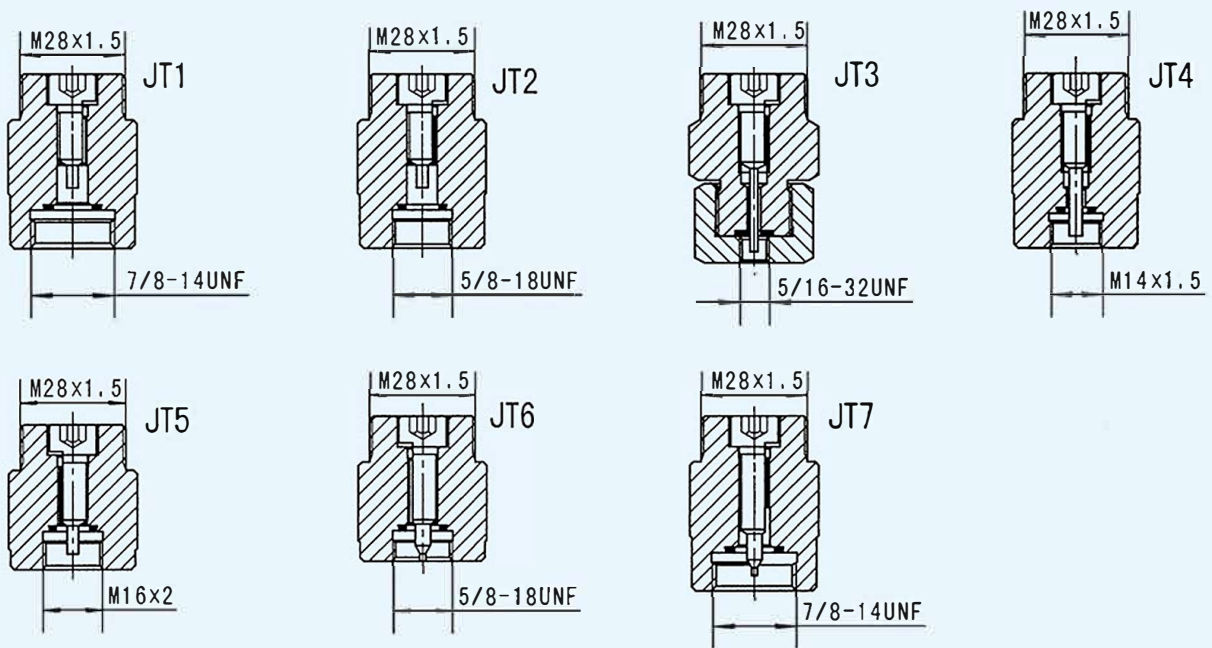

Model	Maximum working pressure(MPa)	Matched pressure gauge		Hose length	Connection thread to accumulator
		Measure range	Precision rate		
FPU-16	10	0-16	2.5	2000	JT1 JT2 JT3 JT4 JT5 JT6 JT7
FPU-25	20	0-25			
FPU-40	31.5	0-40			



Introduction

The SAF series safety block is used between the accumulator and the hydraulic system to control the flow of hydraulic oil to the accumulator, provide overpressure protection, and unload the pressure by releasing the oil.

How to order

SAF	20	M	1	2	Y	1	N	210	A	-	S13
[1]	[2]	[3]	[4]	[5]	[6]	[7]	[8]	[9]	[10]		[11]

- [1] Model: SAF Series Accumulator safety blocks
- [2] Safety and Shut-off Block Size: —10、20、32、50mm
- [3] relief type: M-Manual operation
E-manual and solenoid operation
- [4] Body material: 1-Carbon steel
- [5] Seal material: 2-NBR
6-FKM
- [6] Solenoid model: Y-solenoid operation normally open
Z-solenoid operation normally closed
- [7] Solenoid Voltage type: 1-24VDC
3-220VAC
- [8] Relief valve: N-can be adjusted by wrench
- [9] Pressure setting: Max. pressure 330bar
- [10] Threads connection stand: A-ISO228 (BSP)
- [11] Adapter for accumulators: see accessories at five pages after

Circuit diagram

Manual operation

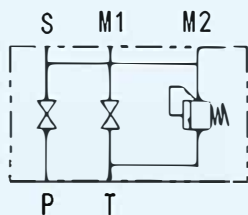

Manual and electromagnetic operation normally open

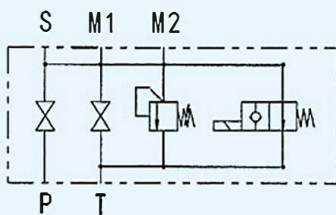

Manual and electromagnetic operation normally close

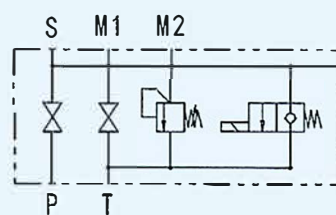

General dimensions

Safety and Shut-off Block Size 10

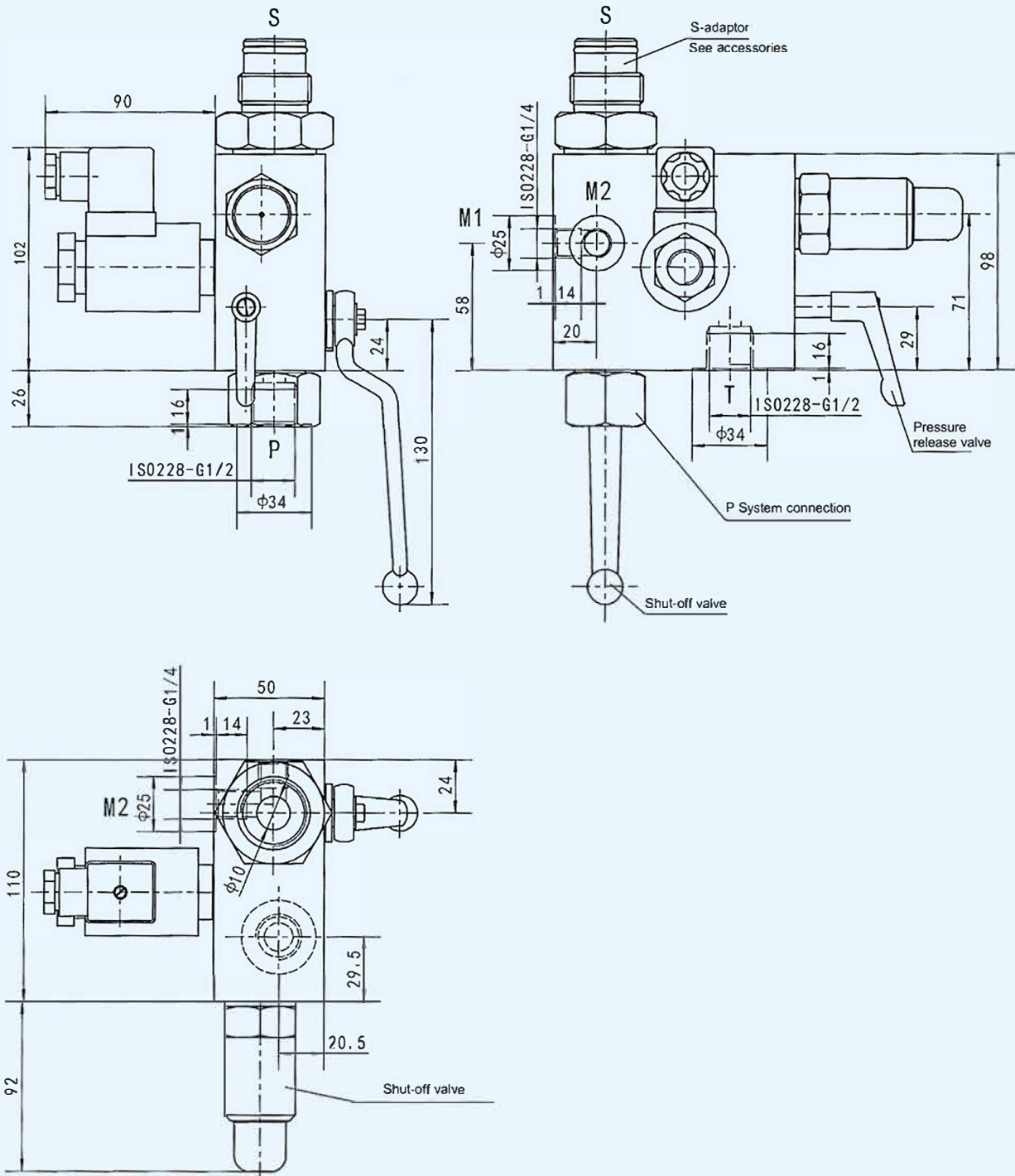

 General dimensions

Safety and Shut-off Block Size 20

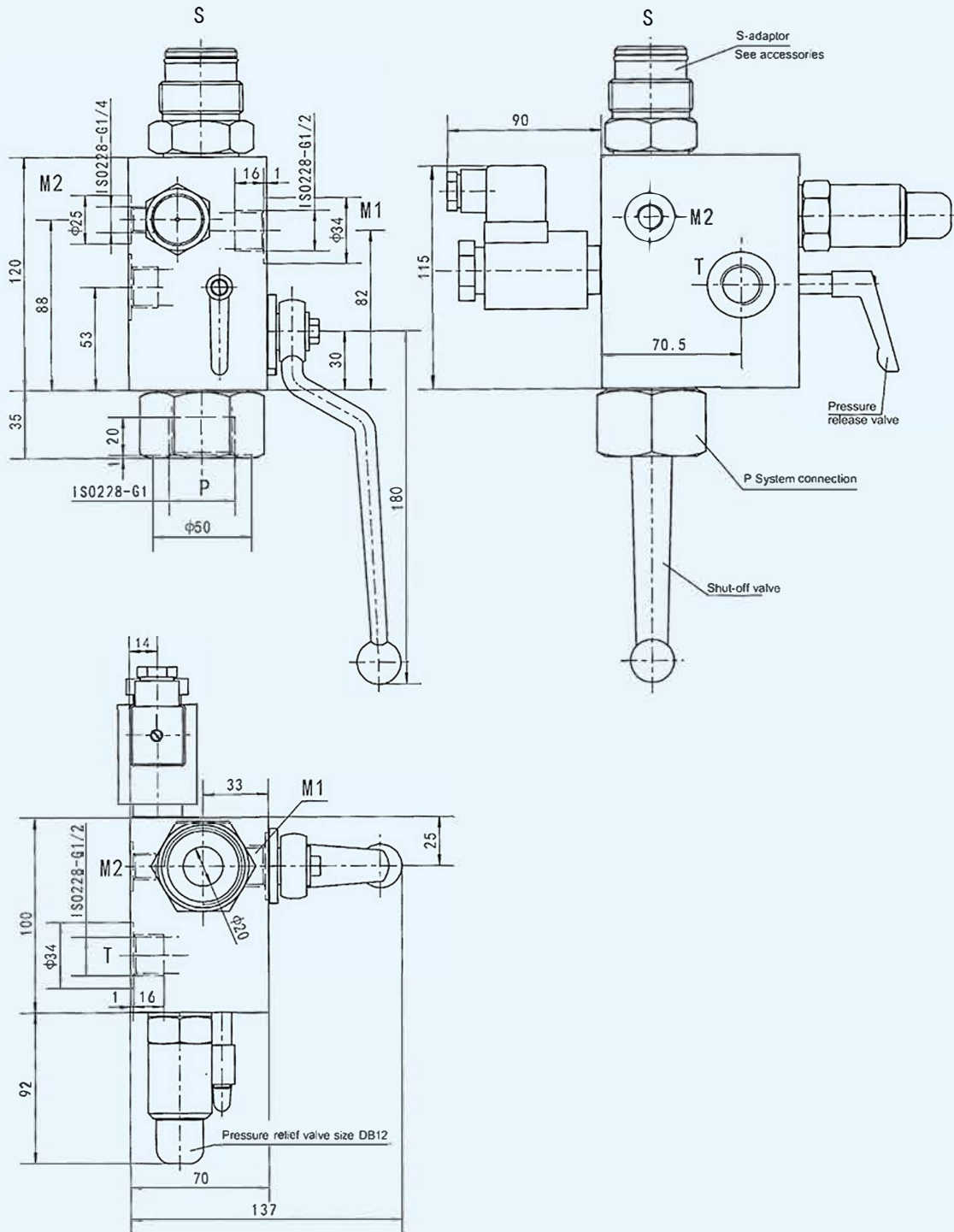

 General dimensions

Safety and Shut-off Block Size 32

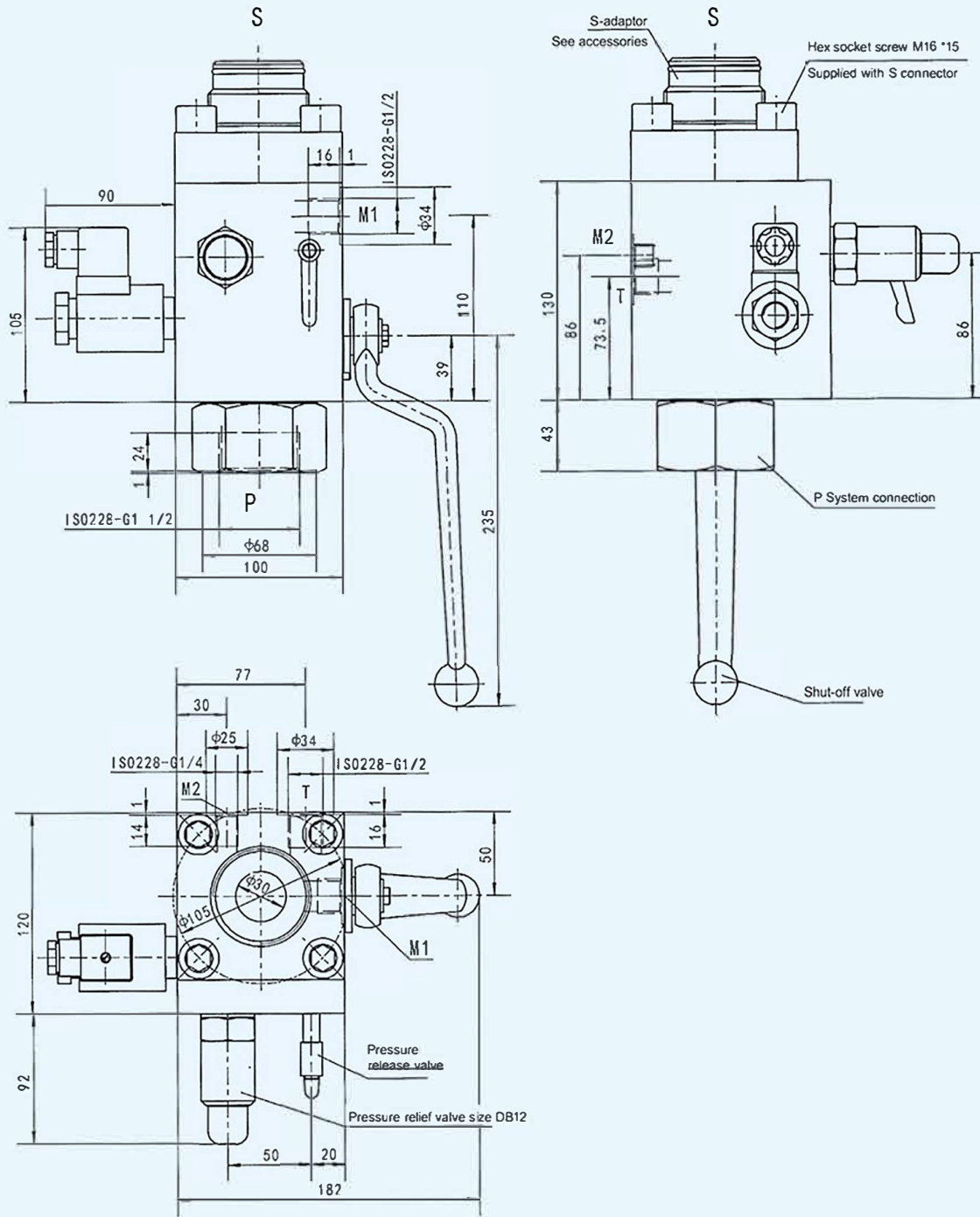

 General dimensions

Safety and Shut-off Block Size 50

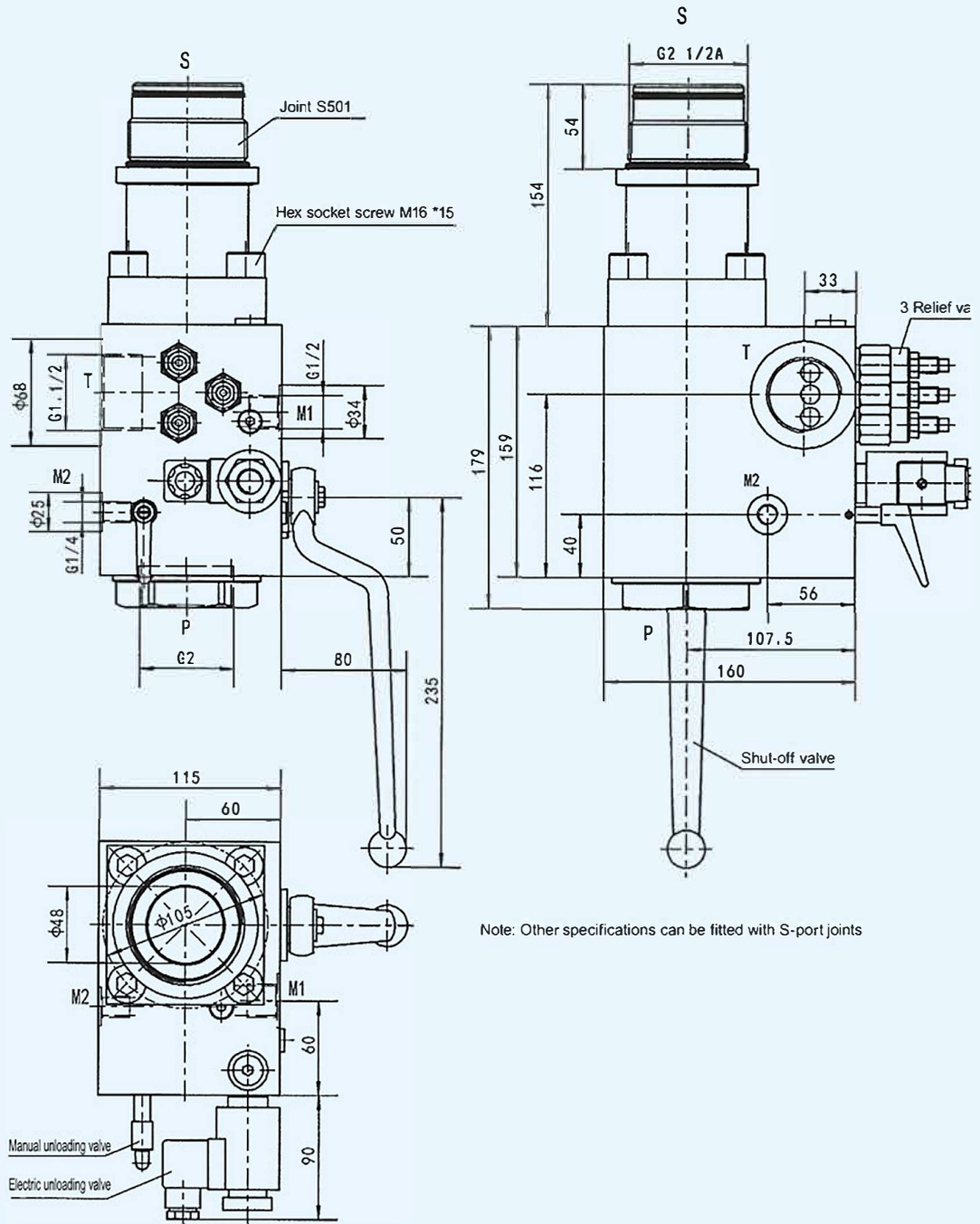

Note: Other specifications can be fitted with S-port joints

Accessories (Adaptor for SAF to connect the safety and shut-off block with the accumulator)

1. Adapter for standard bladder accumulator

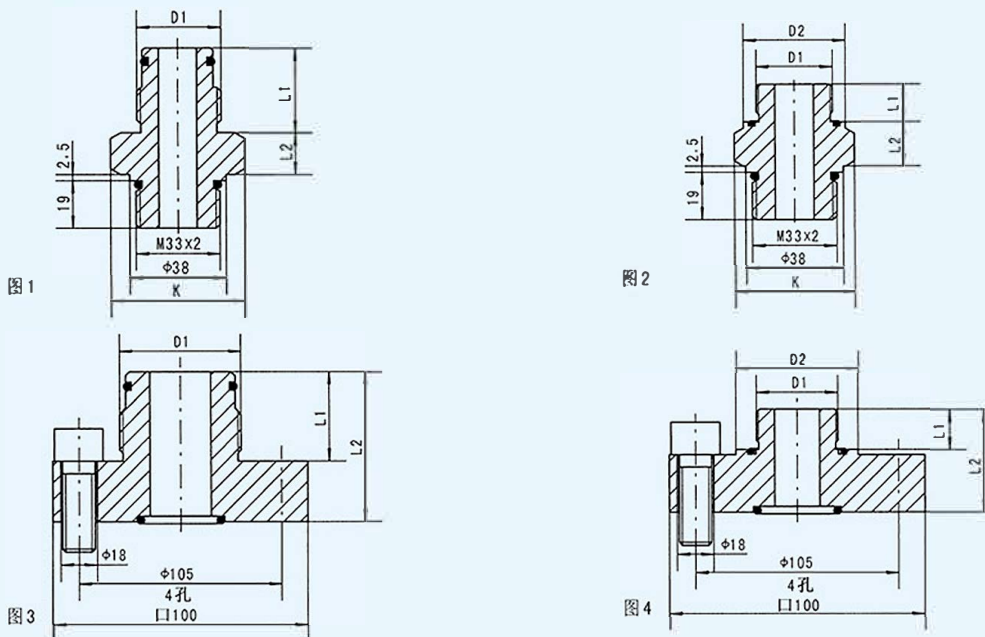

Model	Accumulator Model	D1 Thread	Adaptor	Diag.no	K (sw)	L1 (mm)	L2 (mm)	D2 (mm)
SAF10/20	SB330/400-0.5 to 1L	G ³ /4A	S10	1	41	28	15.5	
	SB550/600-1 to 5L	G1A	S11		46	34	16.5	
	SB330/400-2.5 to 5L	G1 ¹ /4A	S12			37		
	SB330/400-10 to 50L	G2A	S13		65	44	20.5	
	SB440/500/600-10 to 50L							
Connection with metric fine thread	M30×1.5	S20	2	41	15	17.5	40	
	M40×1.5	S21		55	20	20.5	54	
	M50×1.5	S22		65	20	20.5	64	
SAF32	SB330/400-0.5 to 1L	G ³ /4A	S305	3		28	58	
	SB550/600-1 to 5L	G 1A	S306			34	64	
	SB330/400-2.5 to 5L	G1 ¹ /4A	S307			37	67	
	SB330/400/600-10 to 50L	G2A	S309			44	74	
	SB440/500-10 to 50L		S308				115	
	Connection with metric fine thread	M30×1.5	S330	4		15	47	45
M40×1.5		S340					60	
M50×1.5		S350			20	51	75	

Note: Adaptor in Diag.3 & Diag.4 supplied with 4 off int.hex.screw M16x45 including O-ring.



2. Adaptor for piston accumulator

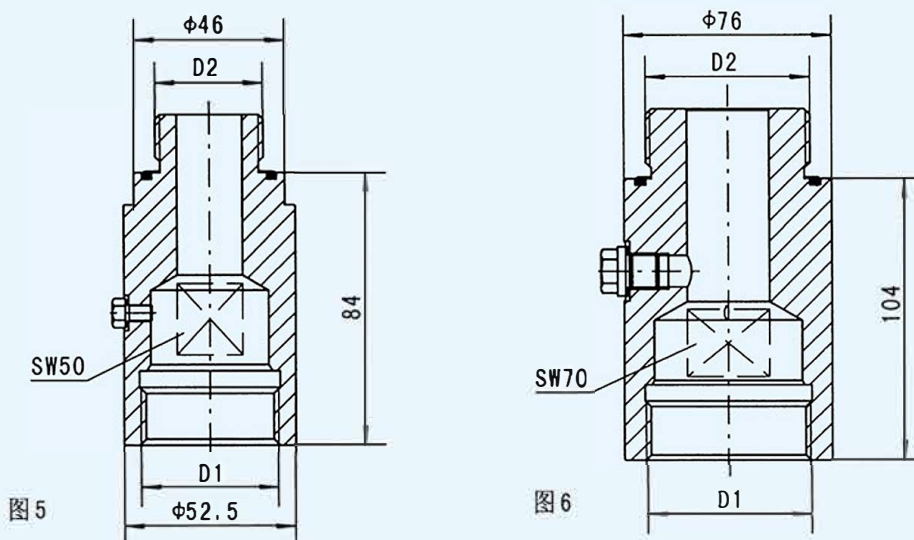

Model	Accumulator Model	Adaptor	Diag.no	D1 Thread	D2 Thread	Corresponding S-adaptor
SAF10/20	SK10/350-2.5 to 7.5L	K406	5	G1 1/4	G1 A	S12
	SK210/350-10 to 45L	K408	6	G2	G1 1/2A	S13
SAF32	SK21/350-50 to 120L	K409			G2A	S309

O-ring supplied as part of adaptor.

3. Adaptor for diaphragm accumulator

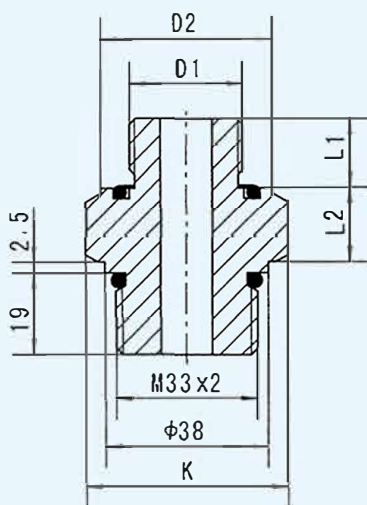

Model	Accumulator Model	D1 Thread	Adaptor	K (SW)	L1 (mm)	L2 (mm)	D2 (mm)
SAF10/20	SBO...E-0.075 to 1.4L	G1/2A	S30	41	14	17.5	33
	SBO...A6-0.1 to 210-1.3L						
	SBO...E2.0 to 3.5L	G3/4A	S31	41	16	17.5	40
	SBO...A6-400-1.3 to 4L						

O-ring supplied as part of adaptor.



Bladder accumulator assembly schematic

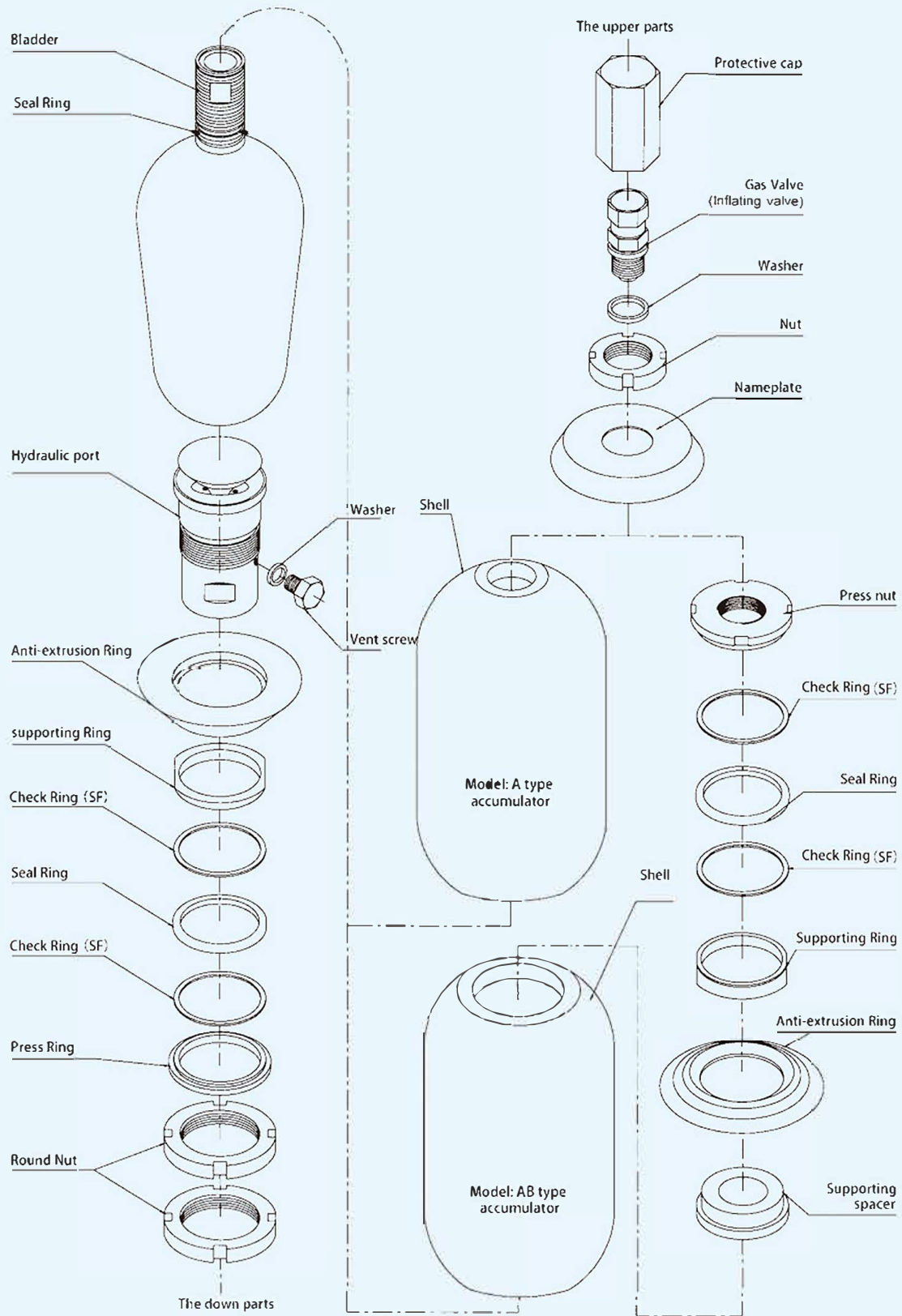



How to order

M	B	□	/	□
[1]	[2]	[3]		[4]

- [1] ASME
- [2] B: Bottom Repair
T: Top Repair
- [3] Nominal Volume (Gal)
- [4] Nominal Pressure (Psi)

Specification

- [1] Construction: Bottom repair , top repair
- [2] Fixation way: Clamp or bracket
- [3] Installation: vertical
- [4] Medium: Hydraulic oil, emulsion
- [5] Operating temperature: -10°C ~+93°C
- [6] Gas charged in the bladder : Nitrogen

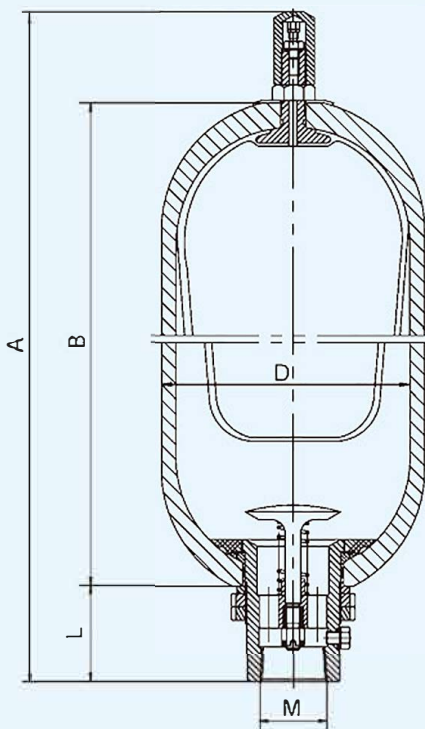

Bottom Repair Construction

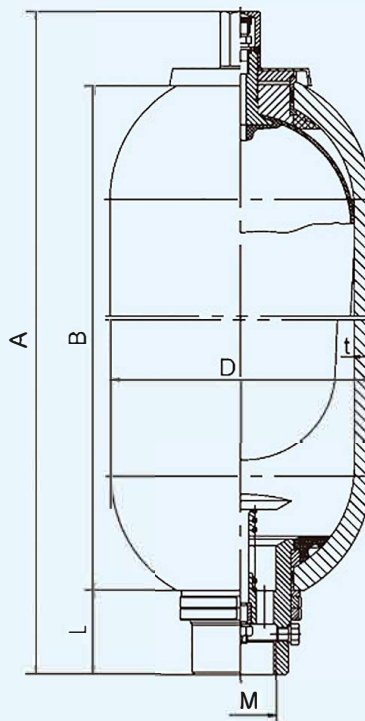

Top Repair Construction



Model Code and Size (ASME)

Model Code	Pressure (MPa)	Volume (L)		Weight (kg)		Size (mm)				
	Psi	Gal	L	Lbs	Kg	D (mm)	L (mm)	A (mm)	B (mm)	M (NPT)
MB0.25/3000	3000	0.25	1	11	5	Φ114	50	325	195	3/4"
MB1/3000		1	4	32	14.5	Φ168	60	385	315	1 1/4"
MB2.5/3000		2.5	10	95	43	Φ229	87	585	425	2"
MB5/3000		5	19	140	64			865	710	
MB10/3000		10	38	230	104			1435	1280	
MB11/3000		11	42	240	109			1540	1385	
MB14/3000		14	53	276	126			1875	1720	
MB15/3000		15	57	290	132			1985	1830	
MT2.5/3000		2.5	10	95	43			580	420	
MT5/3000		5	19	140	64			855	710	
MT10/3000		10	38	230	104			1425	1280	
MT11/3000		11	42	240	109			1530	1385	
MT14/3000		14	53	276	126	1865	1720			
MT15/3000		15	57	290	132	1975	1830			
MT16/3000		16	63	380	171	1485	1305	2-1/2"		
MT21/3000		21	80	473	213	Φ299	106		1825	1645
MT26/3000		26	100	562	253	2205	2025	3"		
MT17/3000		17	63	377	170	Φ351	110		1185	985
MT21/3000		21	80	457	206				1410	1210
MT26/3000		26	100	555	250				1675	1475
MT33/3000	33	125	675	304	2005				1805	
MT39/3000	39	150	791	356	2325			2125		
MT48/3000	48	180	933	420	2715	2515				
MT53/3000	53	200	1035	466	2995	2795				
MB0.25/4500	4500	0.25	1	12	5.5	Φ114	50	325	195	3/4"
MB1/4500		1	4	44	20	Φ168	60	385	315	1 1/4"
MB2.5/4500		2.5	10	128	58	Φ232	87	585	425	2"
MB5/4500		5	19	185	84			855	700	
MB10/4500		10	38	300	136			1435	1280	
MB11/4500		11	42	322	146			1540	1385	
MB14/4500		14	53	392	178			1935	1780	
MB15/4500		15	57	403	183			2005	1850	
MT2.5/4500		2.5	10	128	58			545	400	
MT5/4500		5	19	185	84			845	700	
MT10/4500		10	38	300	136			1425	1280	
MT11/4500		11	42	322	146			1530	1385	
MT14/4500		14	53	392	178	1925	1780			
MT15/4500		15	57	403	183	1995	1850			
MT16/4500		16	61	422.4	192	1460	1280	2-1/2"		
MT21/4500		21	80	510.4	232	Φ299	74		1800	1620
MT26/4500		26	100	602.8	274	2180	2000	2"		
MT2.5/5000		2.5	10	90.6	41	Φ232	87		580	420
MT5/5000		5	19	169	76				860	700
MT6.4/5000		6.4	24	181.6	82.2				1002	857
MT10/5000	10	38	267	121	1425				1280	
MT11/5000	11	42	276	125	1530			1385		

Ordering note: If you have special requirements, please contact our company for advice.



How to order

PED	□	/	34.5
[1]	[2]	[3]	

- [1] European Standard Accumulators
- [2] Nominal Volume (L)
- [3] Nominal Pressure : 34.5MPa

Specification

- [1] Construction: Bottom repair , top repair
- [2] Fixation way: Clamp or bracket
- [3] Installation: vertical
- [4] Medium: Hydraulic oil, emulsion
- [5] Operating temperature: -10°C ~+70°C
- [6] Gas charged in the bladder : Nitrogen

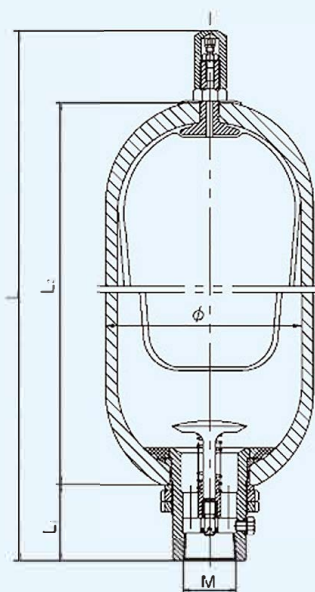

Bottom Repair Construction

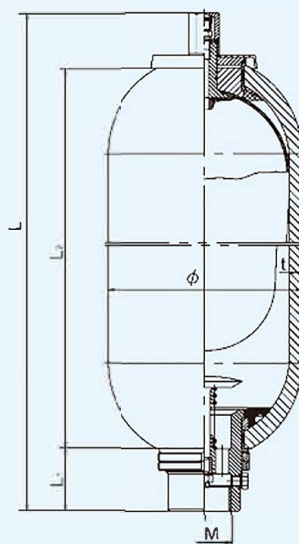

Top Repair Construction

Model Code	Pressure (MPa)	Volume (L)	Weight (kg)	Size (mm)				
				Φ	L1	L2	L	M
PED1/34.5	34.5	1	5.5	Φ114	47	197	302	G3/4
PED2/34.5		2	6			315	445	
PED4/34.5		4	11	Φ168	63	315	447	G1 1/4
PED6/34.5		6	15.5			410	532	
PED10/34.5		10	37	Φ229	86	427	587	G2
PED15/34.5		15	49			582	742	
PED20/34.5		20	61			737	897	
PED24/34.5		24	70			857	1017	
PED32/34.5		32	95			1107	1267	
PED40/34.5		40	105			1354	1514	
PED50/34.5		50	117			1663	1823	



Model Code and Size

NXQ-A type threaded hydraulic port construction diagram of accumulator
NXQ-A-*/*/L-*

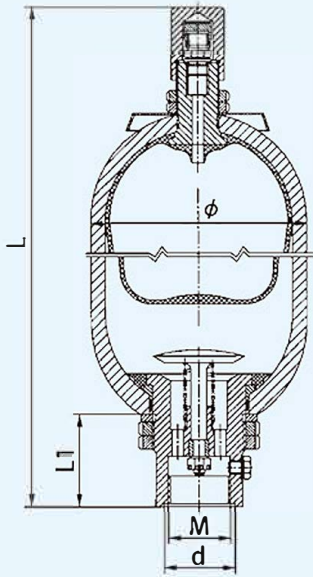

NXQ-AB type threaded hydraulic port construction diagram of accumulator
NXQ-AB-*/*/L-*

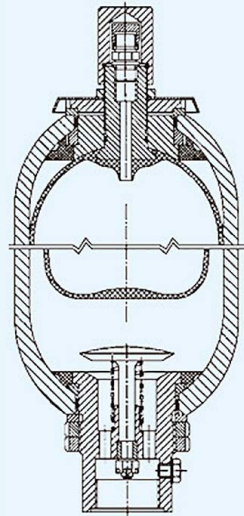

NXQ-A(AB) type flanged hydraulic port construction diagram of accumulator
NXQ-A(AB)-*/*/F-*

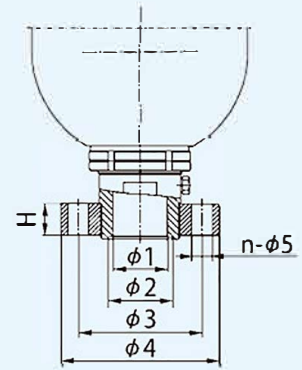

Model Code	Nominal Pressure (MPa)	Nominal Volume (L)	Size (mm)										Weight (kg)			
			M	d	φ1	φ2	φ3	φ4	n-φ5	L1	H	Hydraulic Port		φ		
												Thread			Flange	
												L				
NXQ-A-1.6*/L(F)-*	10	1.6	M42×2	50	42	50	97	130	6-φ17	66	28	365	380	152	11	
NXQ-A-2.5*/L(F)-*		2.5										430	445		14	
NXQ-A-4*/L(F)-*		4										540	555		16	
NXQ-A-6.3*/L(F)-*		6.3										710	725		22	
NXQ-*-10*/L(F)-*		20	10	M60×2	72	55	65	125	160	6-φ21	90	32	650	665	219	39
NXQ-*-16*/L(F)-*			16										860	875		54
NXQ-*-20*/L(F)-*			20										985	1000		62
NXQ-*-25*/L(F)-*			25										1160	1175		74
NXQ-*-32*/L(F)-*			32	1400	1415	90										
NXQ-*-40*/L(F)-*			40	1680	1695	108										
NXQ-*-50*/L(F)-*	50		2010	2025	128											
NXQ-*-20*/L(F)-*	31.5		20	M72×2	80	70	80	150	200	6-φ26	106	40	660	675	299	80
NXQ-*-25*/L(F)-*			25										750	765		90
NXQ-*-40*/L(F)-*			40										1030	1045		118
NXQ-*-50*/L(F)-*		50	1210										1225	138		
NXQ-*-63*/L(F)-*		63	1450										1465	171		
NXQ-*-80*/L(F)-*		80	1290										1805	213		
NXQ-*-100*/L(F)-*		100	2170										2185	253		
NXQ-*-150*/L(F)-*		150	3105										3120	335		

Ordering note: If you have special requirements, please contact our company for advice.



(ABS American Bureau Of Shipping Certification) Accumulators

Model Code and Size

NXQ-A type threaded hydraulic port construction diagram of accumulator
NXQ-A-*/*/L-*

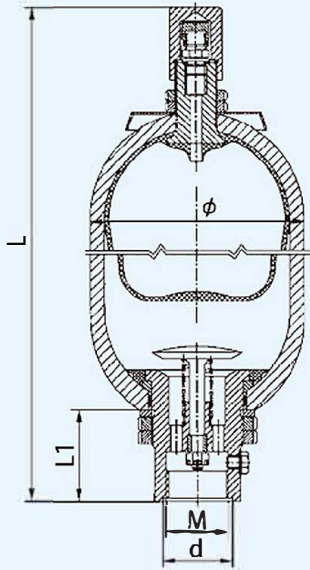

NXQ-AB type threaded hydraulic port construction diagram of accumulator
NXQ-AB-*/*/L-*

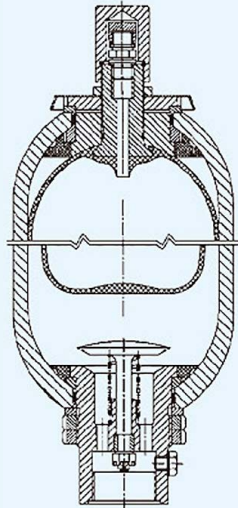

NXQ-A(AB) type flanged hydraulic port construction diagram of accumulator
NXQ-A(AB)-*/*/F-*

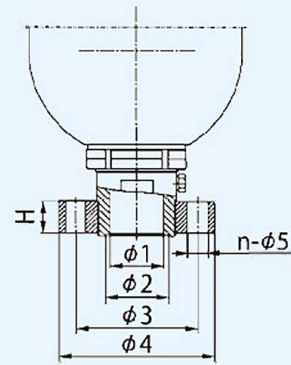

Model Code	Nominal Pressure (MPa)	Nominal Volume (L)	Size (mm)										Hydraulic Port		Weight (kg)
			M	d	Φ1	Φ2	Φ3	Φ4	n-Φ5	L1	H	Thread	Flange	Φ	
												L			
NXQ-A-1.6/*-L(F)-*	10	1.6	M42×2	50	42	50	97	130	6-Φ17	66	28	365	380	152	11
NXQ-A-2.5/*-L(F)-*		2.5										430	445		14
NXQ-A-4/*-L(F)-*		4										540	555		16
NXQ-A-6.3/*-L(F)-*		6.3										710	725		22
NXQ-*-10/*-L(F)-*		10										650	665		39
NXQ-*-16/*-L(F)-*	16	860	875	54											
NXQ-*-20/*-L(F)-*	20	985	1000	62											
NXQ-*-25/*-L(F)-*	20	25	M60×2	72	55	65	125	160	6-Φ21	90	32	1160	1175	219	74
NXQ-*-32/*-L(F)-*		32										1400	1415		90
NXQ-*-40/*-L(F)-*		40										1680	1695		108
NXQ-*-50/*-L(F)-*		50										2010	2025		128
NXQ-*-20/*-L(F)-*		20										660	675		80
NXQ-*-25/*-L(F)-*	31.5	25	M72×2	80	70	80	150	200	6-Φ26	106	40	750	765	299	90
NXQ-*-40/*-L(F)-*		40										1030	1045		118
NXQ-*-50/*-L(F)-*		50										1210	1225		138
NXQ-*-63/*-L(F)-*		63										1450	1465		171
NXQ-*-80/*-L(F)-*		80										1290	1805		213
NXQ-*-100/*-L(F)-*	100	2170	2185	253											
NXQ-*-150/*-L(F)-*	150	3105	3120	335											

Ordering note: If you have special requirements, please contact our company for advice.



How to order

AD **A** □ / □ **1** / **1**
 [1] [2] [3] [4] [5] [6]

[1] Welded diaphragm accumulators

[2] Construction

A: Rechargeable

B: Completely sealed

[3] Nominal Volume (L)

[4] Max. allowable working pressure

[5] Shell Material: 1 – Carbon steel

[6] Diaphragm Material code

1-NBR

2-HNBR

3-IIR

4-EPDM

5-FKM

6-CR

7-ECO

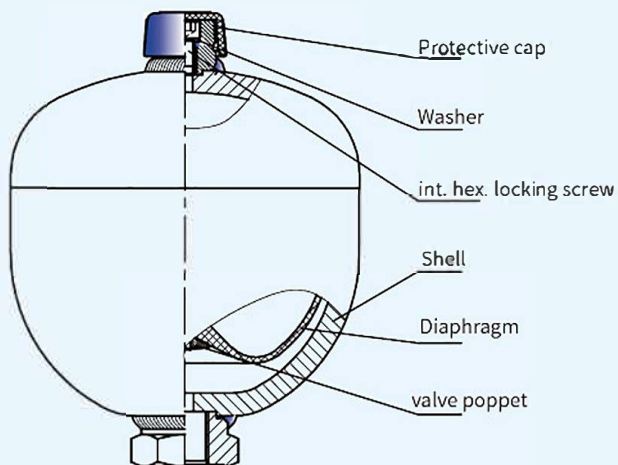

Welded Diaphragm accumulator use steel stamping shell ,
 They have two types according to the gas side: Rechargeable
 or completely sealed.





Welded Diaphragm accumulator Illustration

Symbol	Type	Gas side connection		Oil side connection*
1			B	
2			-	
3			-	

Welded Diaphragm accumulator size chart

Nominal Volume (L)	Allowable compression ratio P2:P0	Allowable pressure bar	R mm	ΦD mm	Weight (kg)	Gas side connection	Standard fluid connection						symbol
							F mm	ΦG mm	L mm	B mm	Hex. mm	H mm	
0.075	8: 1	210	88	65	0.7	A	-	-	12	27	22	G3/8	1
0.16	8: 1	210	95	75	0.85	A	-	-	14	29	27	M18×1.5	1
0.25	8: 1	100	109	80	0.8	A	-	-	15	28.5	27	G1/2	1
	8: 1	250	112	86	1.2	A	G1/2	-	22	20	32	-	2
0.32	8: 1	210	119	95	1.32	A	G1/2	-	22	20	32	-	2
	8: 1	210	101	95	1.4	B	-	-	15	28.5	27	G1/2	1
0.35	8: 1	100	102	89	1.0	B	-	-	15	28.5	27	G1/2	1
0.5	8: 1	210	132	106	2.2	A	G1/2	34	24	22	41	-	3
0.75	8: 1	210	148	121	3.0	A	G1/2	34	24	22	41	-	3
1.0	8: 1	210	162	142	5.0	A	G1/2	34	24	22	41	-	3
1.4	4: 1	210	173	153	5.9	A	G1/2	34	24	22	41	-	3
2.0	4: 1	250	205	172	9.2	A	G3/4	40	30	28	46	-	3
2.8	4: 1	250	255	172	11	A	G3/4	40	30	28	46	-	3
3.5	4: 1	210	286	172	13.8	A	G3/4	40	30	28	46	-	3
4.0	4: 1	210	317	172	15.2	A	G3/4	40	30	28	46	-	3